

THE BUILDING DECARBONIZATION PRACTICE GUIDE

A Zero Carbon Future for the Built Environment



VOLUME 1+2:

Introduction

Universal Design, Construction, and Operational Phase Considerations

VOLUME 1+2 CONTENT LEADERSHIP

- » **Miranda Gardiner**, AIA, iMasons
Climate Accord
- » **Steven Guttman**, PE, BCxP, LEED Fellow,
Guttman & Blaevoet
- » **Heidi Lubin**, eSix Development
- » **Alice Sung**, AIA, LEED AP BD+C, SEA,
Greenbank Associates
- » **Wolfgang Werner**, AIA, LEED AP BD+C,
CPHD, Urban Fabrick, Inc
- » **Tamim Younos**, Green Water-Infrastructure
Academy

ACKNOWLEDGEMENTS

The William J. Worthen Foundation would like to thank the entire Working Group of experts behind the development of the Building Decarbonization Practice Guide.

RELEASE DATE

9/14/2021 (Updated 8/31/2023)

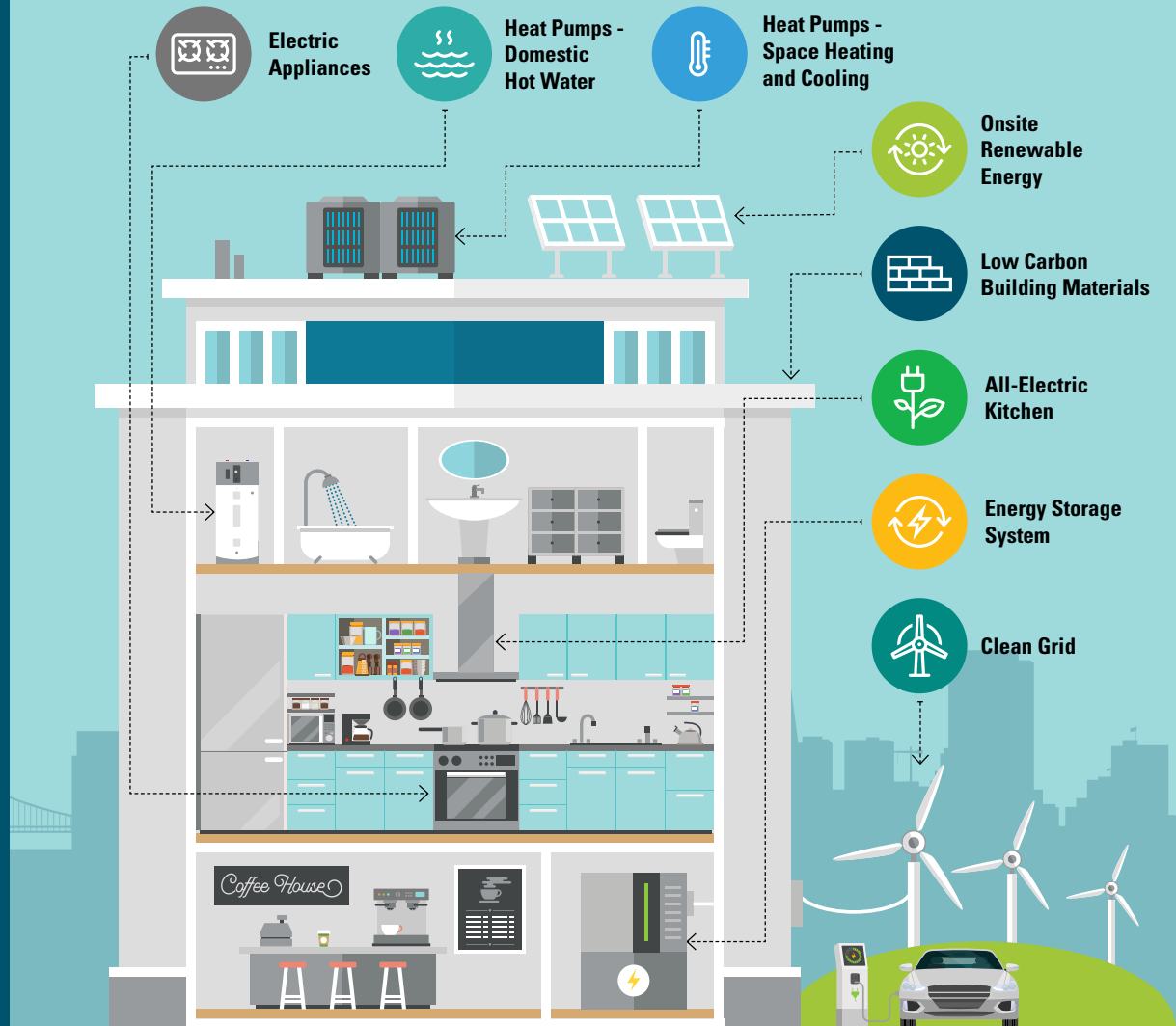

DISCLAIMER: This practice guide is for educational purposes only. The strategies discussed are addressed in general terms, and should only be applied to a project with the assistance of properly trained professionals who can advise on their applicability to a project, and the results that can be expected from their application. Use of the contents of this guide is done at the sole risk of the user, and the William J. Worthen Foundation, the Building Decarbonization Practice Guide Working Group members, and our project sponsors are not responsible for any consequences or benefits arising from the use of, reference to, or reliance on the practice guide's contents. Downloading and use of this document is subject to the Terms of Use published on the Foundation's website as they are subject to change without notice (a copy of the Terms of Use, current at the time of publication, are included at the end of this document).



Table of Contents

VOLUME 1: INTRODUCTION

1.0	Introduction	4
1.1	The Background of the Global Climate Crisis	5
1.2	Why Focus on the Built Environment?	6
1.3	Decarbonization and Electrification	10
1.4	How This Guide Can Assist with Your Own Decarbonization Efforts	11

VOLUME 2: UNIVERSAL DESIGN, CONSTRUCTION, AND OPERATIONAL PHASE CONSIDERATIONS

2.0	Universal Design, Construction, and Operational Phase Considerations	13
2.1	To Build or Not	14
2.2	Equity and Social Justice Considerations	15
2.3	Assembling the Right Team	19
2.4	Owner's Project Requirements: The Value of Goal Setting	23
2.5	Using Building Performance Modeling as a Design Guidance Tool	27
2.6	Design Approaches	36
2.7	Construction Practices	69
2.8	Post-Construction Practices	71
	Acknowledgments: Project Sponsors, Contributors, and Terms of Use	74





VOLUME 1

Introduction



1.1_The Background of the Global Climate Crisis

1.1.1_HOW DID WE GET HERE?

Since the onset of the Industrial Revolution a multitude of human activities has led to an inexorable increase in heat-trapping greenhouse gas concentrations in our atmosphere. In recent decades, this warming has accelerated at an alarming rate and threatens the survival of the biosphere that supports life as we know it. The unprecedented rate of industrial and population growth over the last two centuries and the near-complete transformation of the world from largely agrarian societies to highly urbanized and industrialized environments was made possible by the exploitation of one critical resource (aside from human ingenuity): fossil fuels.

Devising ways to harness the tremendous energy stored for millions of years in coal, oil, and gas deposits led to the modern world we live in. But the burning of fossil fuels comes with a hugely significant environmental impact: the release of carbon dioxide and other greenhouse gases, causing the warming of our planet. For much of the 19th and 20th centuries, it was easy to ignore this environmental impact, but as we move toward the middle of the 21st century our very survival depends on ultimately phasing out fossil fuel use.

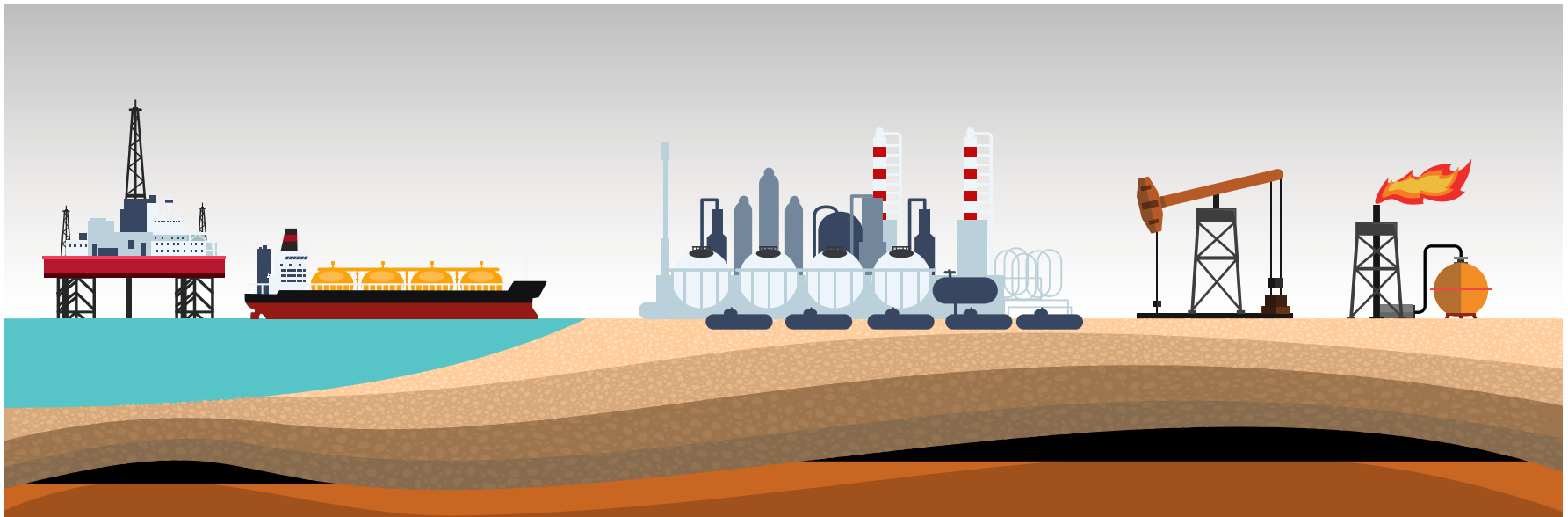

1.1.2_ WHAT IS CLIMATE CHANGE AND GLOBAL WARMING

Climate change is attributed to global warming caused by increased concentration of greenhouse gases (GHGs) in Earth's atmosphere. GHGs warm the Earth by absorbing energy and slowing the rate at which the energy escapes to space. Critical GHGs are carbon dioxide (CO₂), methane (CH₄), nitrous oxide, and refrigerants. CO₂ is considered the major GHG contributing to global warming. Recent focus has also been placed on methane leakage; due to Global Warming Potential (GWP) and recent data on leakage from its entire production and distribution cycle, cutting methane emissions may be the fastest opportunity we have to immediately slow the rate of global warming, even as we decarbonize our energy systems.

The Global Warming Potential of GHGs was developed to allow comparisons of the global warming impacts of different gases. Specifically, it is a measure of how much energy the emissions of 1 ton of a gas will absorb over a given period of time, relative to the emissions of 1 ton of CO₂. The time period usually used for GWPs is 100 years. For example, CH₄ is estimated to have a GWP of 28–36 over 100 years. GWPs provide a common unit of measure, which allows analysts to add up emissions estimates of different gases (e.g., to compile a national GHG inventory), and allows policymakers to compare emissions reduction opportunities across sectors and gases. The US EPA tracks total U.S. emissions by publishing the *Inventory of U.S. Greenhouse Gas Emissions and Sinks*. This annual report estimates the total national greenhouse gas emissions and removals associated with human activities across the United States.¹

In the US, GHG emissions from burning of fossil fuels are distributed across several economic sectors as categorized by the EPA (see Figure 1.1): electricity (generation, transmission and distribution), agriculture (crop and livestock production for food), industry (production of the goods and raw materials we use), transportation (the movement of people and goods by

cars, trucks, trains, ships, airplanes, and other vehicles), and residential and commercial (both direct emissions from fossil fuel combustion, and indirect emissions that occur offsite but are associated with use of electricity consumed by homes and businesses).²

FIGURE 1.1: TOTAL U.S. GREENHOUSE GAS EMISSIONS BY ECONOMIC SECTOR

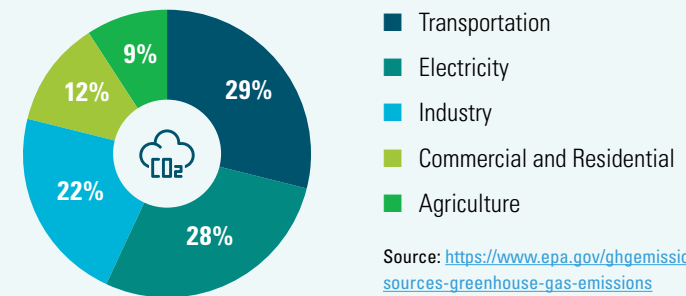

1.2_ Why Focus on the Built Environment?

Virtually all areas of human endeavor — agricultural and industrial processes, manufacturing, transportation and shipping, waste management, and the construction and operation of our entire built environment — rely to some extent on the energy of fossil fuels. This last sector is the focus of this practice guide. In the United States overall, approximately 35% of the nation's 2019 carbon footprint was a result of energy use in buildings³ (and almost 50% when including embodied carbon), and in densely populated public-transportation-reliant cities this percentage can be a lot higher. For example, in New York City energy use in buildings accounts for almost 75%.⁴

¹ <https://www.epa.gov/ghgemissions/understanding-global-warming-potentials>

² <https://www.epa.gov/ghgemissions/inventory-us-greenhouse-gas-emissions-and-sinks>

³ <https://www.eia.gov/environment/emissions/carbon/>

⁴ https://www.nyc.gov/html/gbee/downloads/pdf/TWGREport_2ndEdition_sm.pdf

1.0_INTRODUCTION

With global building stock projected to double in area by 2060,⁵ it follows that reversing the growth of greenhouse gas emissions will require a coordinated, rapid, and scalable effort from the entire community of professionals that regulate, conceive, fund, design, construct, operate, maintain, and deconstruct the built environment.

1.2.1_HOW BUILDINGS USE ENERGY: OPERATIONAL ENERGY + CARBON

Fossil fuels can be used either directly or indirectly in building operations. For example, a residential building may have a gas or oil-fired boiler in the basement combusting fossil fuel on-site to produce hot water. In this example, greenhouse gases are released directly by the building. Conversely, other end uses in buildings, such as lighting, air conditioning, or consumer electronics, typically use electricity as fuel. This electricity is generally supplied by a local utility company that operates remote power plants to generate electricity which is supplied to its customers through a network of transmission lines, transformer stations, and related infrastructure; the so-called “grid.”

When plugging a television into a wall outlet, it is not apparent which mix of primary energy the utility company used in its network of power plants to generate the electricity feeding the TV. This primary energy fuel mix used by a utility for a certain region is referred to as the “grid mix.” It is a safe bet that, in most locales, the grid mix is still reliant on fossil fuels (i.e. that the power plants are using coal or natural gas to generate steam that spins a turbine which generates the grid electricity). Thus, the greenhouse gas emissions associated with the TV’s use of electricity are generated remotely at the power plant.

From 1990 to 2015, CO₂ emissions from fossil-fuel combustion attributed to the operation of buildings in general, and residential buildings in particular, increased 7.8 percent and 20.4 percent respectively. The majority of these emissions are indirect emissions from electricity generated off-site to power buildings. The remainder are direct emissions, primarily from on-site combustion of fossil fuels for heating, hot water, and cooking, and from leaks of compounds used in refrigeration and air conditioning (see Figure 1.2).⁶

FIGURE 1.2: TOTAL CO₂ EMISSIONS FROM THE COMMERCIAL AND RESIDENTIAL SECTORS (2016)

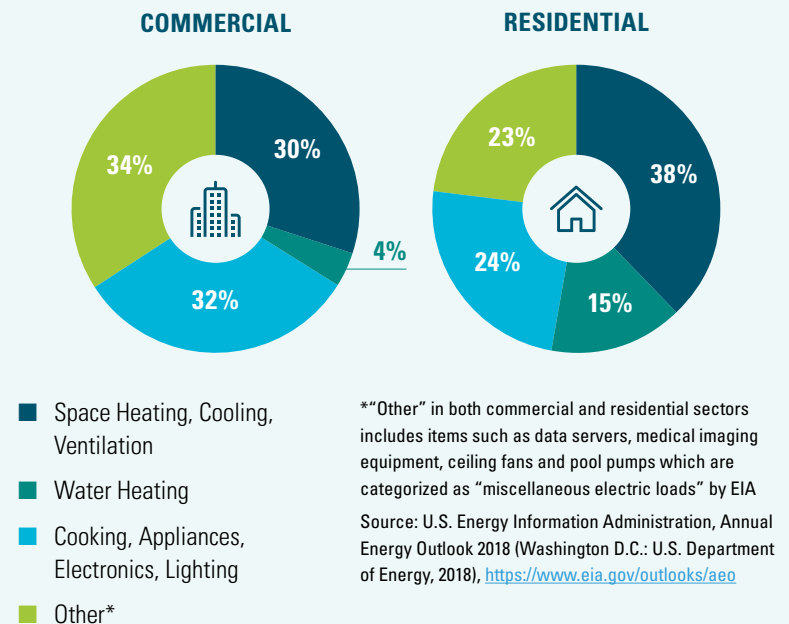

⁵ https://architecture2030.org/buildings_problem_why/

⁶ Center for Climate and Energy Solutions (C2ES) — Decarbonizing U.S. Buildings | <https://www.c2es.org/document/decarbonizing-u-s-buildings/>

1.0_INTRODUCTION

In 2015, CO₂ emissions from on-site fossil-fuel combustion in the U.S. building sector generated 565.8 million metric tons of carbon dioxide equivalent (MMt CO₂e in direct emissions), or about 8.6 percent of total U.S. greenhouse gas emissions (see Figure 1.3). When indirect emissions (from the electricity generated off-site) are factored in, residential and commercial buildings generated 1,913.3 MMt CO₂e, or 29 percent of total U.S. emissions. The largest increases have been in indirect emissions, driven largely by population growth.

Emissions have been relatively flat since 2010. Thus, moving the U.S. electricity system to power generation that emits zero carbon will only reduce total US emissions around 30%. So, widespread electrification of buildings (new and existing) will be essential to achieving the aggressive goals necessary to significantly mitigate the effects of human-induced climate change.

A variety of residential and commercial end uses contribute to these sectors' energy demand, and corresponding CO₂ emissions. Space heating, cooling and ventilation, water heating, cooking, appliances, electronics, other plug loads, and lighting are the largest end uses (see illustration to the right). Satisfying these loads without direct or indirect emissions from fossil fuel use is the defining challenge of our time for the design and construction industry.

1.2.2_HOW BUILDINGS USE ENERGY: EMBODIED ENERGY + CARBON

Embodied carbon refers to the greenhouse gas emissions arising from the manufacturing, installation, maintenance, and disposal of construction materials used in the construction of buildings, roads, and other infrastructure. It should come as no surprise that the materials needed for creating buildings are very energy-intensive (think about ore mining, steel mills, and cement plants, for example). As such, there is a substantial amount of carbon emissions “embodied” in these materials as a result of the energy used to extract, manufacture and deliver them to a construction project. The term “embodied carbon” reflects all the emissions resulting

FIGURE 1.3: CARBON EMISSIONS OF FOSSIL FUEL END USES IN U.S. BUILDINGS (2015)

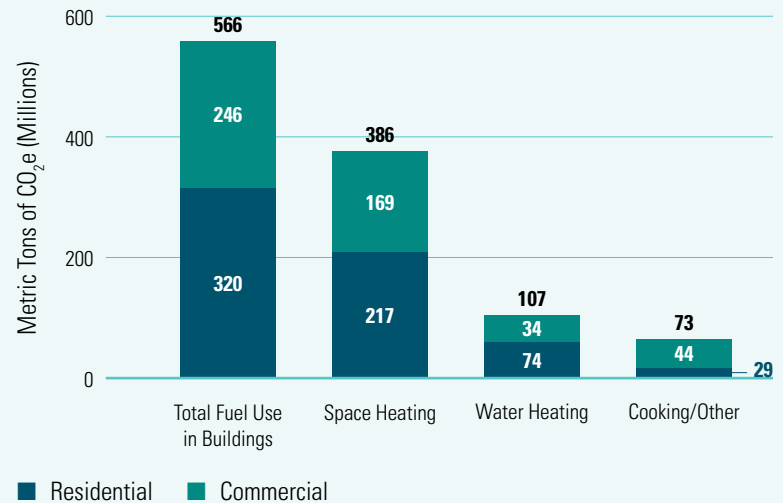

Source: The Economics of Electrifying Buildings, RMI 2018

from the materials and construction processes that go into a specific building. Embodied carbon is an ‘up front’ cost that can be as large as multiple years of emissions from a building’s operational energy, as the figure below demonstrates (see Figure 1.4).

FIGURE 1.4: RELATIONSHIP BETWEEN EMBODIED CARBON AND OPERATIONAL CARBON OVER A BUILDING’S LIFECYCLE

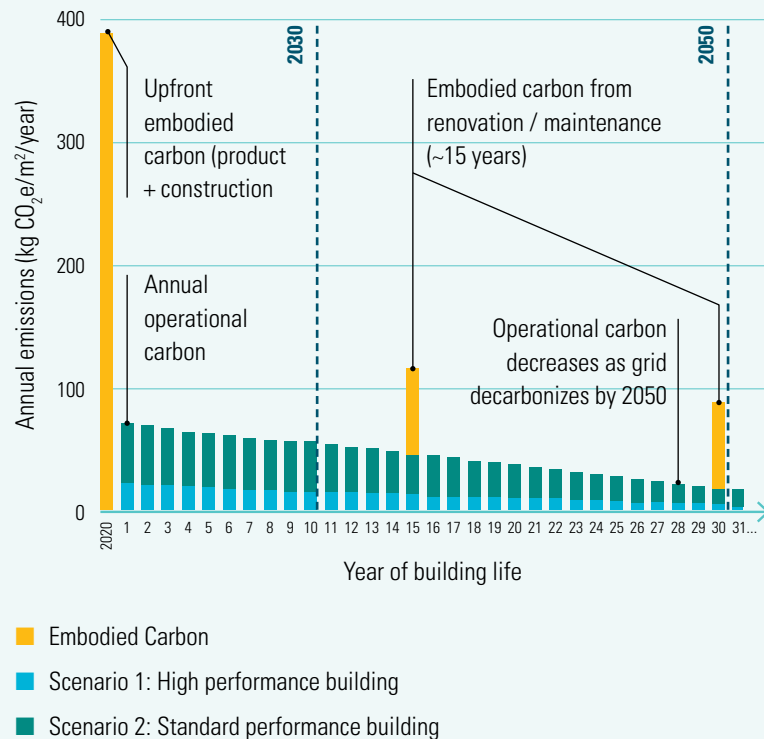

Source: Carbon Leadership Forum

According to the statistics compiled by Architecture 2030, embodied carbon was responsible for 11% of global GHG emissions and 28% of global building sector emissions in 2017. Projections for the period 2020 to 2050, based on business as usual, suggest that embodied carbon may represent almost 50% of all the emissions from new construction over the next 30 years, and almost three-quarters of all construction-related emissions over the next decade (see Figure 1.5). Clearly, embodied carbon requires immediate and close attention if we are to meet the desired carbon emissions reduction targets in the next ten years.

FIGURE 1.5: TOTAL CARBON EMISSIONS OF GLOBAL CONSTRUCTION (2020–2050)

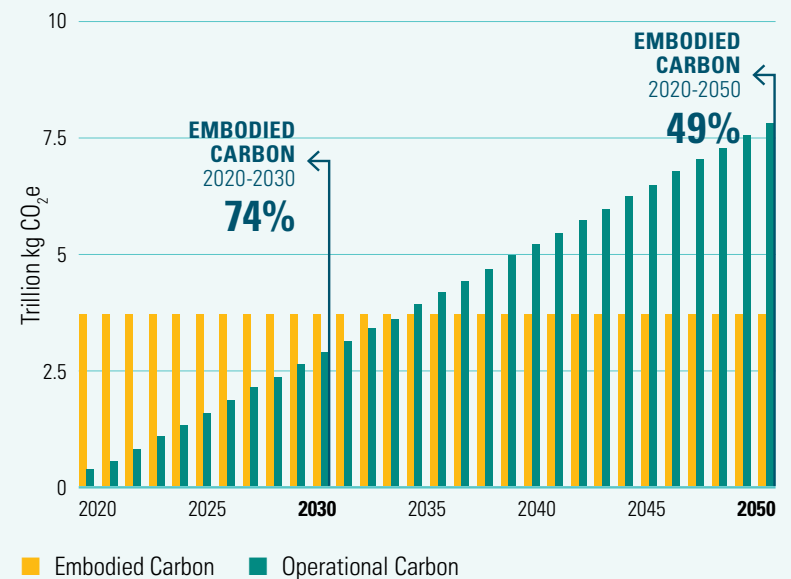

Source: Architecture 2030 (<https://architecture2030.org/new-buildings-embodied/>), using data from the U.N. Environment Global Status Report 2017: EIA International Energy Outlook 2017

Emissions from concrete manufacturing alone accounts for 8% of global greenhouse gas emissions,⁷ and the embodied carbon intensity (embodied carbon content per square foot constructed) of each building material can change with each design decision. Sustainable manufacturing, material selection and reuse, local sourcing, and construction methods are all choices that have impacts on the embodied carbon intensity of a building.

Pairing the carbon impacts of material extraction, manufacturing, transportation, and end of life choices with operational carbon impacts from energy use and refrigerant selection is increasingly important to understand the total carbon emissions of each building.

WHAT DO WE MEAN WHEN WE TALK ABOUT BUILDING DECARBONIZATION?

Decarbonization: in the utility sector, it means reducing the carbon intensity of the emissions per each unit of energy which is generated. In the construction sector, it means reducing the greenhouse gas emissions that are attributable to the construction and operations of a building.

Electrification: in the context of this practice guide, this means relying on electricity as the only energy source used to power the equipment that enables a building to function and meet its intended use.

Operational Carbon: the carbon emissions attributable to the operations, the operational, or in-use phase of a building.

Embodied Carbon: the carbon emissions from the entire life cycle (e.g. manufacture, transport, erection, and disposal) of a material used in the construction of a building or other infrastructure of the built environment.

Carbon Negative: when a facility is removing more carbon from the atmosphere than it emits each year. Also referred to as “Climate Positive” and “CarbonPositive.”

Carbon Neutral: having no net release of carbon dioxide to the atmosphere from a facility, especially through offsetting emissions (e.g. by planting trees or producing more solar energy than is used by the facility).

Emissions: in this document, “carbon emissions” and “GHG emissions” are shorthand for “carbon dioxide equivalent emissions” or CO₂e.

Zero Emissions: unlike carbon neutral buildings, which can still emit greenhouse gases, “zero emissions” buildings emit ZERO pounds of greenhouse gasses annually.

1.3_Decarbonization and Electrification

Decarbonization refers to the construction of a new building (or alteration of an existing one) in a manner that reduces the GHG emissions related to the building’s erection and operation. This can be achieved in a number of ways, but, historically, the focus has been on reducing building-related energy use through energy efficiency measures, as well as satisfying the remaining energy use from renewable energy sources. In recent years, approaches have shifted to achieving “carbon neutral” construction through building electrification, material selections that reduce embodied carbon, and paying back the embodied carbon “debt” by producing more energy than the building consumes from renewable energy sources.

As the cost of photovoltaic (PV) systems drops, constructing all electric buildings served by electricity from 100% renewable energy sources can now be done cost effectively. Over the past decade, data compiled by the US DOE’s National Renewable Energy Lab shows a steady decline in the cost of PV systems (a 65% reduction in the price of residential systems, and a 70% reduction for commercial systems). The U.S. DOE’s Solar Energy Technologies Office (SETO) data demonstrates that the unsubsidized cost of producing electricity with PV systems (which was \$0.10 per kW-hr in

⁷ Lehne, Johanna; Preston, Felix (June 2018). “Making Concrete Change: Innovation in Low Carbon Cement and Concrete” (PDF). Chatham House. *Chatham House Report*. ISBN 9781784132729. Retrieved 2021-04-17

2019) was cheaper than the average utility rate in at least 23 States. While the rates for all other forms of electricity are projected to increase over the next decade (as well as the relative cost of alternative fuels for onsite combustion, such as hydrogen, biofuels, etc.), SETO projects that by 2030 unsubsidized costs for PV systems will reach \$0.04 per kW-hr, making solar energy cheaper than any other energy source.

As a result of these source energy cost dynamics, anyone attempting to construct or renovate a building that is part of the global efforts to address climate change must recognize that the sensible path to decarbonize buildings is through electrification, low carbon material selection, and net-positive renewable energy production.

The purpose of the Building Decarbonization Practice Guide is to identify and explain these principles, to offer guidance to owners, regulators, and design and construction professionals, and to share helpful lessons learned so that our industry as a whole can help realize a zero net carbon future for the built environment.

1.4_How this Guide is Organized

The seven volumes of the practice guide will help readers to understand the context for building electrification and decarbonization, how strategies vary by building type, how to approach key systems and services that have traditionally been powered by onsite fossil fuel combustion, how to engage in addressing embodied carbon, and what implications for future decarbonization efforts result from the current Codes and Policy landscape.

FIGURE 1.6: COMMON ELEMENTS OF LOW CARBON CONSTRUCTION

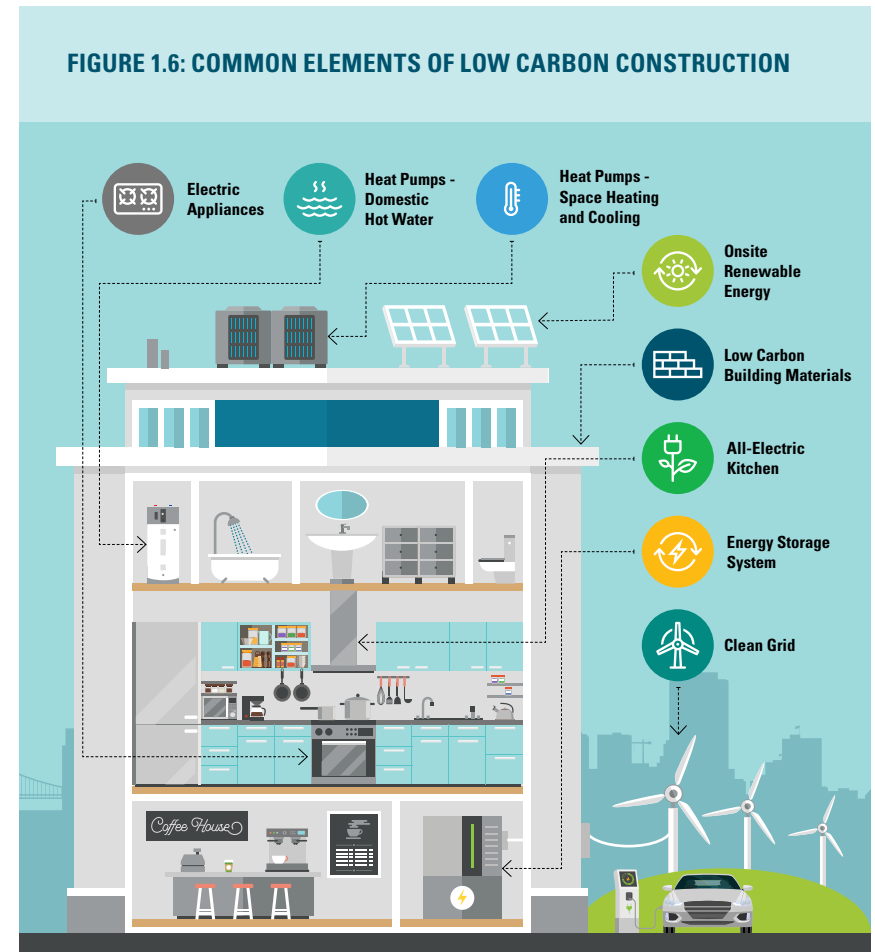

- 1. Volume 1, Introduction:** this Volume provides context, background and definitions.
- 2. Volume 2, Universal Design, Construction, and Operational Phase Considerations:** this Volume describes the factors related to electrification and decarbonization that are common to most, if not all, occupancy and building types.
- 3. Volume 3, Multi-Family Residential, Hotels/Motels, and Similar Buildings:** this Volume discusses issues that are unique to this occupancy type, both new construction and existing building renovations. It addresses planning, budgeting, design, construction, and operations.
- 4. Volume 4, Commercial + Institutional Buildings:** this Volume discusses issues that are unique to commercial buildings, both new construction and existing building renovations. It addresses planning, budgeting, design, construction, and operations.
- 5. Volume 5, All-Electric Kitchens — Residential and Commercial:** since kitchens, both commercial and residential, present some of the hardest design and operational paradigms to change, they warrant a Volume of their own. This Volume describes all-electric kitchen technologies, trade-offs between various options, and the potential barriers to adoption (including how to overcome them).
- 6. Volume 6, Embodied Carbon:** the preceding volumes focus largely on operational carbon, so this Volume goes into depth on embodied carbon, including background, definitions, and information on design decisions and product selection that are applicable to all building types.
- 7. Volume 7, Resources:** This volume contains a summary of all the reference material used in the development of the various volumes of the Guide. In addition, it contains new resources related to code and policy development for use by governmental agencies and corporate sustainability leaders. The code and policy resource section has some additional narrative to highlight important considerations for anyone working to advance decarbonization using code and policy levers.



VOLUME 2

Universal Design, Construction, and Operational Phase Considerations



2.0_UNIVERSAL DESIGN, CONSTRUCTION, AND OPERATIONAL PHASE CONSIDERATIONS

Regardless of the project type — be it a large multifamily residential development, a new or renovated office building, university housing with a big central kitchen, or a state-of-the-art public library — there will be numerous common design, construction and operational strategies, approaches, elements and technologies to consider when seeking to minimize operational and embodied carbon. This Volume will explore the key concepts that are relevant to all project types (see Figure 2.1).

FIGURE 2.1: COMMON ELEMENTS OF LOW CARBON CONSTRUCTION

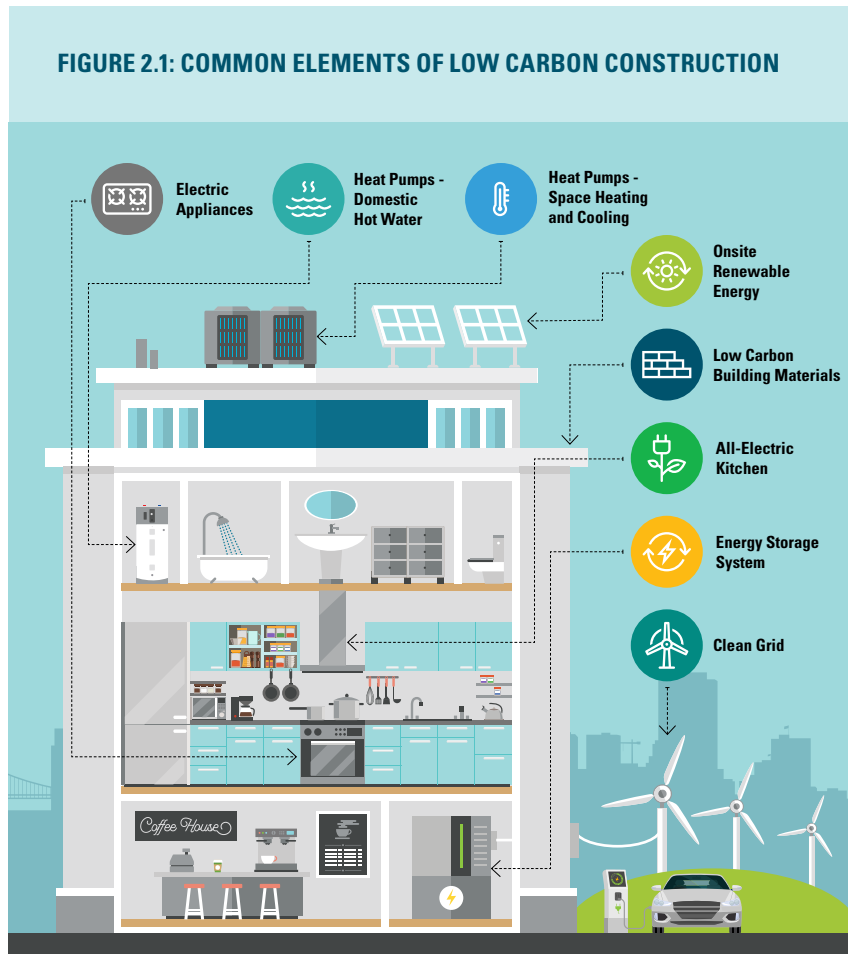

2.1_To Build or Not

IS BUILDING NECESSARY?

This practice guide is focused on how to build “responsibly.” Alternatives for building generally include renovation, adaptive reuse, and new construction. How to avoid building altogether (i.e. choosing whether to renovate, or adapt an existing building to a new use) is a topic for another practice guide. For the purposes of our focus on moving towards a carbon neutral future, this practice guide evaluates ways to eliminate operational carbon — through building systems electrification combined with the use of electricity from 100% renewable energy sources — and to significantly reduce embodied carbon. We will attempt to be clear where the strategies discussed in this Guide will be usable or best suited for only renovation or new construction. We will also attempt to be clear about what is required to adapt certain strategies for one building alternative or another. Otherwise, the following strategies should be seen as equally applicable to new construction and renovation/adaptive reuse projects.

EXISTING BUILDINGS

Choosing to decarbonize an existing building versus pursuing new, low-carbon construction requires a delicate balance between the embodied carbon benefits of an existing building and the potential for deep operational carbon improvements. The embodied carbon impact of renovating an existing building is usually lower, since the quantity of new virgin material is smaller and less waste is sent to landfills. However, providing a high performance envelope that allows for significant reductions in HVAC system capacities, or even elimination of some systems (e.g., perimeter heating systems), can often be extremely expensive in renovation projects.

In existing buildings, the easiest action — “the lowest hanging fruit” — is to ensure that lighting systems are replaced with very high efficiency, low wattage LED lighting: paybacks on lighting retrofits are extremely short in the context of building energy efficiency investment options (often less than two years). Heating and cooling systems represent the next largest energy

savings opportunity, but these upgrades can be complex. If this upgrade is not in the cards as part of a facility improvement, it should be planned as a long-term or phased replacement project rather than abandoning this opportunity altogether. Upgrading these systems as part of an initial facility improvement is more easily justified when mechanical systems are at the end of useful life.

Replacing the building facade elements of existing buildings is another level of improvement that should be carefully evaluated with respect to carbon impacts. The long-term operational carbon benefits should outweigh the embodied carbon “costs,” unless these changes are being driven by other factors such as improvements in occupant comfort or when the building skin is no longer weathertight. Investments in envelope improvements also can reduce the cost of new mechanical, electric, and plumbing (MEP) systems and mitigate some of the challenges associated with meeting heating loads in an all-electric building design.

2.2_Equity and Social Justice Considerations

While the rest of this Practice Guide is largely technical in nature, this section is intended to plant the seed for advancement of the equity and social justice considerations that are essential to a just transition of our built environment to a zero carbon future.

Building “responsibly” cannot be accomplished without considering both the community that a building is intended to serve (usually too narrowly defined as the “users” and adjacent properties by a project client/owner) and the larger human community in which the building will be located. While the benefits to the users — as well as to the adjacent properties and neighborhood- may be relatively evident, the opportunity to improve equity in the built environment for the larger human community (especially communities of concern) also needs to be considered. How these

“Equity means fairness. Equity... means that peoples’ needs guide the distribution of opportunities for well-being. Equity... is not the same as equality... Inequities occur as a consequence of differences in opportunity, which result, for example in unequal access to health services, nutritious food or adequate housing. In such cases, inequalities... arise as a consequence of inequities in opportunities in life.”

Adapted by Liz Ogbu from “Glossary of Terms,” from the Public Health Agency of Canada, retrieved from <http://www.phac-aspc.gc.ca/php-ppsp/ccph-cesp/glos-eng.php>. The glossary was compiled by Dr. John M. Last in October 2006 and revised and edited by Peggy Edwards in August 2007. This quote has been edited to remove references to public health, since the belief is that the same notion applies to the design field and to society more broadly. For her full article, “Using Our Words: The Language of Design for Equity” see <https://nextcity.org/urbanist-news/using-our-words-the-language-of-design-for-equity>.



2.0_ UNIVERSAL DESIGN, CONSTRUCTION, AND OPERATIONAL PHASE CONSIDERATIONS

“communities” are defined, and how potential negative impacts to communities of concern are considered and addressed, can prevent adverse outcomes that would otherwise result in increasing socio-economic inequities, unintended harms, or both. Depending on the ownership, nature, and location of a project, existing inequities in our built environment can be perpetuated. For example, new building developments in already wealthy and segregated locations — however green or carbon neutral in design — may only increase the inequitable access to, or unfair distribution of opportunities and/or healthy environments. New building developments or renovations in existing low income, segregated communities of concern may cause displacement of existing frontline and/or low-income residents or building occupants — via unwanted ownership changes or rent increases. Such projects can contribute to the gentrification of neighborhoods and, in the process, adversely impact existing local communities.

Approaches to these challenges can include resident/occupant protections, such as first rights of re-occupation without an increase in rent, and Community Benefits Agreements (CBAs). Other approaches may be identified and defined by members of the communities of concern themselves through meaningful community engagement. Furthermore, “Targeted Universalism” can be applied to the implementation of building decarbonization goals, as well as broader environmental or social justice work (see <https://belonging.berkeley.edu/targeted-universalism>). Within a Targeted Universalism framework, universal goals — such as “just and equitable decarbonization of the built environment” — are established. How the universal goals are achieved requires targeted strategies that are dependent on the specific context in order to center justice and equity (see Figure 2.2). The strategies to achieve the universal goals should specifically consider communities of concern based upon how they have been historically and cumulatively impacted, as well as how they are situated within systemic structures, culture, and across geographies.

FIGURE 2.2: FROM INEQUALITY TO EQUITY TOWARDS JUSTICE

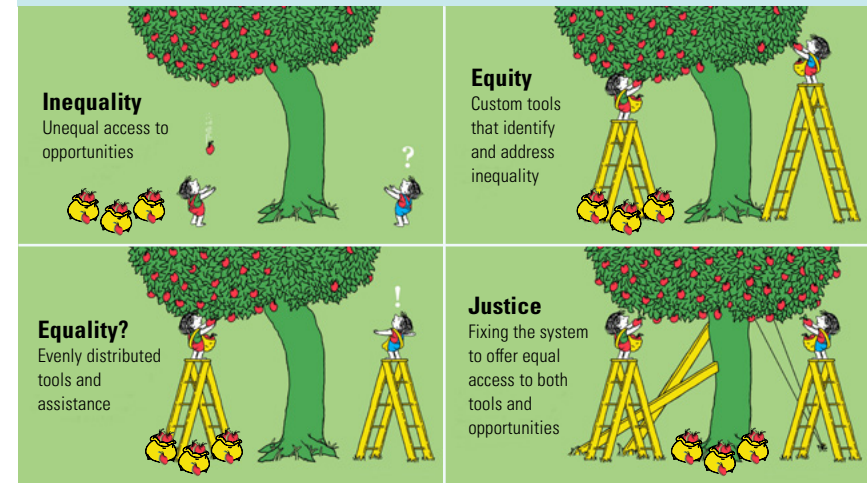

As you view and begin to think about the definitions, systems conditions, or systems changes that each of these four images represent, notice in particular, that in the final “Justice” image, the system itself is transformed in which the tree is straightened to favor neither the left or the right side, and the density of apples is evenly distributed. The people on both sides are now able to pick the equally accessible apples, and the historic piles of apples, accumulated only on the left side, are redistributed to be shared in abundance amongst both people. What else do you notice in this graphic? What else might be missing?

Source: Design in Tech Report, 2019 (https://designintech.report/wp-content/uploads/2019/03/dit2019_v00.pdf) with similar apologies to Shel Silverstein. Reprinted by permission of Common Spark Consulting with modifications by Dr. Anthony Kinslow II and S. Sikand.

2.0_ UNIVERSAL DESIGN, CONSTRUCTION, AND OPERATIONAL PHASE CONSIDERATIONS

Thus, enlightened project development should identify universal goals and utilize targeted strategies within a planned framework to level the playing field and strive towards justice and equity. Such an approach ensures that all communities of people have access to racial and “spatial” justice¹, equitable, sustainable, and ecologically sound development, and empathic and human-centered design² — all without exacerbating extant inequities.

It matters who benefits just as much as how communities benefit from improvements to the built environment. Universal goals need to address project outcomes from a health equity, as well as economic and social perspectives. Historically, frontline communities have — through both policy and law – been forced to live, work, learn, and play in some of the most neglected, polluted environments, and within the least healthy buildings. Thus, positive outcomes for low income and communities of concern should be prioritized. In order to advance equitable building decarbonization, these communities should share in implementation leadership — from the planning, design, and construction to the maintenance and operations of building projects. This vision for a just transition needs considerably more attention as we collectively seek to integrate equity and climate justice into our policies, projects, program design and everyday practices.

2.2.1_ SOCIETAL BENEFITS

There is a growing awareness of the societal benefits (or co-benefits) of public sector actions focused on GHG emissions reductions (see Figure 2.3). As the public costs of extreme weather events grow, public expenditures for GHG emissions reduction strategies will have a positive return on investment while being essential to avoiding the worst impacts of climate change.³ These returns will come primarily from the avoided costs of disaster mitigation and reductions in health care costs borne by the public health care system.

¹ See https://en.wikipedia.org/wiki/Spatial_justice and <http://www.jssj.org/>

² From “Using Our Words: The Language of Design for Equity” | <https://nextcity.org/daily/entry/using-our-words-the-language-of-design-for-equity>

³ According to NOAA’s National Center for Environmental Information, as of July 2023, the U.S. has sustained 360 weather and climate disasters since 1980 where overall damages/costs reached or exceeded \$1 billion (including CPI adjustment to 2023). The total cost of these 360 events exceeds \$2.570 trillion (<https://www.ncei.noaa.gov/access/billions/>).

FIGURE 2.3: SOCIETAL BENEFITS OF BUILDING ELECTRIFICATION (FUEL-SWITCHING)



Health

no air pollutants from on-site combustion



Safety

reduced hazard risk, especially in earthquake territory



Resilience

all modern gas equipment requires electricity to operate, so gas equipment is not more resilient. In fact, after natural disasters, electricity is restored faster than gas. All-electric buildings are compatible with on-site generation and back-up power systems.



Short-term economic benefits

of job creation and training in an emerging market, influx of employment opportunities in communities

2.0_ UNIVERSAL DESIGN, CONSTRUCTION, AND OPERATIONAL PHASE CONSIDERATIONS

Public sector agencies around the United States have been investigating the impacts to disadvantaged and vulnerable communities in their climate-related planning and funding. The results of a 2018 study by the California Energy Commission, “Exploring Economic Impacts in Long-Term California Energy Scenarios” (<https://www2.energy.ca.gov/2018publications/CEC-500-2018-013/CEC-500-2018-013.pdf>), suggest that the State’s real gross product would increase due to the State’s commitments to a new generation of lower-carbon energy infrastructure and use technologies. The study also concluded that the value of long-term economic benefits from averted deaths and medical care attributable to California’s climate policy is comparable to the direct costs of the State’s entire low-carbon infrastructure buildout. Thus, the state’s climate initiatives — still controversial for some — could be justified solely on public health grounds.

Additional good news from this study is that these public health benefits would accrue to both disadvantaged and non-disadvantaged communities. For example, the study suggests that for every \$1.00 saved from averted morbidity and mortality per disadvantaged community household, non-disadvantaged community households would also save \$0.85. In other words, there are net benefits for all.

There is also clear evidence that disadvantaged households are disproportionately burdened by high levels of criteria pollutant (carbon monoxide, nitrogen dioxide, sulfur dioxide, ground-level ozone, particulate matter, and lead) exposure: for example, that same California study revealed 25 percent higher PM 2.5 particulate matter levels exposure on average. There are many diseases linked to higher exposures of these criteria pollutants: for example, California’s disadvantaged households suffer from 55% higher than average rates of asthma.

Other potential benefits to all communities by increasing investments in decarbonization of the built environment include:

- » Productivity increases from lower criteria pollutant concentrations (for example, work and school attendance and performance).
- » Avoided local temperature increases due to lower GHG emissions. Higher temperatures have been found to negatively impact, among other things, agriculture, income, education, and crime rates.
- » Job creation.

PUBLIC BENEFITS OF DECARBONIZATION

“The evidence is clear — burning less fossil fuel in power plants, cars and buses translates into less air pollution. Less air pollution can help reduce the risk for heart attacks, strokes, asthma attacks and lung cancer and improve pregnancy outcomes.” — **George Daly, Dean Harvard Medical School**

Source: CEC Publication, CEC-500-2018-013, June 2018

2.3_ Assembling the Right Team

Early in the life cycle of most construction projects, a team of design and construction professionals will be hired to help deliver a building that meets the needs of the owner. Some building owners/developers will use the same team over and over again, building relationships of trust and extracting value from the team's familiarity with an owner's expectations. Other owners may go through a selection process, searching for a team that will help bring the unique vision of a project to fruition.

Whatever process is used to build a team, it is critical to recognize that delivering a high-performance, all-electric, low embodied carbon building requires a different skill set and approach than "business as usual."

The value of hiring architects, engineers, and contractors experienced with the new strategies required to deliver energy efficient, all-electric, low embodied carbon buildings cannot be overemphasized, even if it means that these people act in a supportive role to the "business as usual" team. Let's face it: people who have spent their career designing engines for Ferraris are not likely to be hired to develop the drivetrain for a Tesla. This is not a judgement about Ferraris or Teslas: it is just a fact of what it means to develop "expertise."

This practice guide is all about helping share knowledge, but owners should look for consultants with demonstrated expertise in this aspect of building type, just as they typically look for expertise in building function when hiring a team. Seek out MEP consultants who can show a history of using a variety of design approaches (to ensure that they are able to bring the right solutions to a project rather than justify their preferred solution yet again). Also, make sure that they are focused on informed consent from their clients rather than bringing a tendency to over-sell innovation without a track record and project-specific data and justifications. Equally important is to avoid the "safe" choice: MEP consultants who are low-cost, high perceived reliability, low-advocacy, low-innovation, highly-conservative and focused on repetition.

2.3.1_ WHEN TO HIRE CONSULTANTS?

Design and construction efficiency flows from an optimized implementation process. Since the majority of clients are financially driven, the industry typically responds by looking to repeat proven, code-compliant delivery approaches.

Energy efficient, all-electric, low embodied carbon buildings often push the boundaries of a given jurisdiction's Building Codes, involve new technologies, and benefit from innovative delivery practices. These variances from conventional design and construction practice are most effectively addressed with an integrated project delivery process, where architects, engineers, contractors, and specialty consultants — all with the appropriate expertise — work together starting in early design. When the design and construction teams are integrated, and the major players are present throughout the project, this allows consideration of construction costs and cost effective practices to help optimize design decisions.

Furthermore, building projects that meet these decarbonization goals are created with whole building performance in mind. Although it is possible to reduce carbon emissions from operations with a widget approach, whole building energy and carbon modeling processes facilitate a team's ability to maximize low carbon strategies in cost effective ways. Thus, specialists in building performance modeling (both operational and embodied carbon performance) should be brought into the design process early. For an example of a desirable process, see Figure 2.4 on the following page from "The Architect's Guide to Integrating Energy Modeling in the Design Process," published by the American Institute of Architects. This same concept can be expanded from energy modeling to all the modeling that can help address full decarbonization goals.

2.0_UNIVERSAL DESIGN, CONSTRUCTION, AND OPERATIONAL PHASE CONSIDERATIONS

FIGURE 2.4

	Concept Design	Schematic Design	Design Development	Construction Documents	Construction / Post-Occupancy
TEAM GOALS	<p>Use early Design Performance Modeling to help define the goals of the project</p> <p>(Note: Design Performance Modeling could be with component modeling tools or a basic building energy model, but should at this stage address other performance parameters in addition to energy).</p> <p>Define the project requirements, as informed by modeling results</p>	<p>Review financial and performance energy information from model to guide design decisions</p>	<p>Review design alternatives based on initial goals, as informed by modeling results</p> <p>Create baseline and alternatives to choose from</p>	<p>Create documentation needed to accompany energy model results for code compliance</p> <p>Create documentation needed to accompany energy model results for commissioning and metering/monitoring validation</p>	<p>Use results of the as-built model for commissioning</p> <p>Compare results of the as-built model against metered data to look for operating problems</p>
ENERGY MODELING GOALS	<p>Experiment with building siting and orientation</p> <p>Determine the effective envelope constructions</p> <p>Assess the effects of daylighting and other passive strategies</p> <p>Explore ways to reduce loads</p>	<p>Create rough baseline energy model</p> <p>Test energy efficiency measures to determine the lowest possible energy use</p> <p>Set up thermal zones and HVAC options</p>	<p>Create proposed models with system alternatives to choose from</p> <p>Refine, add detail, and modify the models, as needed</p> <p>Provide annual energy use charts and other performance metrics for baseline vs. proposed</p> <p>Evaluate specific products for project</p> <p>Test control strategies</p> <p>Do quality control check on the models</p>	<p>Complete the final design model</p> <p>Do quality control check on the models</p> <p>Create final results documentation needed to submit for code compliance</p>	<p>Complete the as-built model with installed component cut-sheet performance values</p> <p>Collect metered operating data to create a calibrated model to share with outcome-based database</p>
BENEFITS TO CLIENT	<p>Comfort that entire design team united around project goals</p> <p>Use modeling results to make design decisions informed by integrated system performance</p>	<p>Test different options before implementing them</p> <p>Determine the most efficient and cost effective solutions</p>	<p>Determine the most efficient and cost effective solutions</p> <p>Size mechanical equipment correctly</p>	<p>Use energy model as part of LEED or other sustainable design certification application</p> <p>Provide ability to better predict energy use in the building</p>	<p>Provide ability to refine operations to meet reduced energy use goals in the built project</p>

Source: The Architect's Guide to Integrating Energy Modeling in the Design Process. AIA 2010.

2.3.2_COST ESTIMATING

Almost every construction project relies on close monitoring of the probable cost of construction during the design phase. Best practices include development of a cost model before design even begins, and estimates of construction cost are usually developed at major design milestones to ensure that the design is likely to continue to meet the target budget.

Early cost model development for all-electric buildings requires, by its nature, a substantially different allocation of resources between Divisions of work. Depending on the project delivery method, costs may be developed by the construction team, by professional estimators, or by both. Construction teams often rely on their past experience to inform cost estimates, as well as on subcontractors who may or may not have deep experience with the technologies and design solutions being used in all-electric building designs. Construction cost professionals can often bring a more realistic perspective when confronted with more innovative design solutions. The UK, Australia, and some other countries actually license individuals to provide these services; known as a Professional Quantity Surveyor (QS), these licensed individuals are construction industry professionals with expert knowledge on construction costs and contracts. The duties of a Quantity Surveyor can include:

- » Cost estimate, cost planning, and cost management.
- » Analyzing terms and conditions in contracts.
- » Predicting potential risks in the project and taking precautions to mitigate such.
- » Forecasting the costs of different materials needed for the project.
- » Valuation of construction work.
- » Life cycle cost analysis.

Until all-electric design is the norm, it may be appropriate to hire construction cost professionals to provide cost opinions, even if the construction team is preparing estimates. This second estimate can provide a valuable reference point to ensure that estimates are as accurate as possible, and the process of reconciling two estimates — while sometimes painstaking — can enforce a level of rigor that can help projects stay on budget.

In addition, whether it is a commercial, multifamily, for-profit, non-profit or public project, it is important to have an evaluative framework to analyze the cost of all-electric and decarbonized construction for a given property or development for both capital expense (or first cost) and operational expense. There is no building— even those that will be owned by public or non-profit entities — that would not be well served by lowering a building's first and operating costs. However, it is typical for owners to focus on the initial capital expense without placing adequate “value” on potential reductions in operational expenses over the life of a building that can result from building electrification and decarbonization.

Key elements to any development cost framework need to include:

- » Capital Expenses and Savings (hard costs, as well as construction duration impacts and financing costs)
- » Operating Expenses and Savings (ongoing cost)
- » The Impact of Decarbonized and All-electric Construction on a Project's Exit Value
- » The costs associated with utility connections
- » Time for coordination with dual utilities versus one for all-electric design

2.0_ UNIVERSAL DESIGN, CONSTRUCTION, AND OPERATIONAL PHASE CONSIDERATIONS

While there is no “one-size fits all” solution to establishing a cost analysis framework, we recommend the following best practices:

- » Establish a cost framework as a collaborative effort between project ownership and design and construction leadership to outline key parameters of the analysis
- » Identify costs and benefits so they may be categorized by type and intent
- » Calculate costs and benefits over the life of a project, and include (a) capital expenses; (b) operating cost, (c) replacement cost, and — where applicable — (d) exit value
- » Compare costs and benefits by aggregating all of the defined inputs
- » Compare life cycle costs using different assumptions about utility escalation rates and cost of carbon scenarios

The “key,” however, is to perform a sufficiently comprehensive analysis; there is great risk in not giving adequate attention to all of the cost-elements, particularly because it is easy to overweight the capital expense of decarbonized all-electric construction if one is not rigorously analyzing the benefits (e.g. decreased construction time, reduction in infrastructure expenses, improved operating income, lower operational expenses such as insurance, etc.).

Throughout this practice guide, we provide case studies and links to additional property comparables to help you review built examples and to assist your efforts to push back against any cost premium or “complexity premium” you may encounter for electrified and decarbonized construction and development methodologies.

2.3.3_ROLE OF COMMISSIONING AGENTS

Early ground-truthing⁴ of the operational aspects of a building requires that the design team engage the commissioning agent early in the design process. This will better ensure the commissioning agent is familiar with the building’s design intent well before the actual field-commissioning process begins, and it will serve to head off surprises related to equipment/system functionality. Among the important commissioning strategies in the early design phases of a project:

- » Work with the owner to capture all electrification and decarbonization targets in the Owner’s Project Requirements (OPR).
- » Verify that the design team meets the OPR’s goals in the Basis of Design (BOD) and design documents.
- » Review design documents to ensure that the design intent reflected in the BOD is faithfully executed, maximizes clarity and minimizes ambiguity for the future bidders/builders, and provides features that can improve operational efficiency.

If performed by the right team, these efforts can be a key step towards reducing design team risks, schedule delays and construction cost change orders.

2.3.3.1_Building Enclosure Commissioning

Building Enclosure Commissioning (BECx) has become more widely embraced since the publication of guidelines such as the National Institute of Building Sciences Guideline 3, first published in 2006, and the incorporation of this NIBS Guideline into LEED standards in 2010.

⁴ “Ground truth” is a term used in various fields to refer to information provided by direct observation (i.e. empirical evidence) as opposed to information provided by inference.



Hiring a BECx professional, whose sole responsibility is to check that the project enclosure has been designed and installed to the client's project requirements, has been proven to significantly increase the client's chance of receiving an enclosure that helps to meet the project's overall performance goals.

Once fully installed, many layers of enclosure construction that are critical to performance (e.g. insulation, air-barriers, continuity strips at interfaces, etc.) are completely hidden. Design review remains the most cost effective measure to ensure that materials, components, and detailing will meet the performance intent once purchased. Qualified BECx professionals also help with specifying proper enclosure performance requirements and testing protocols, as well as witnessing that all of the soon-to-be-hidden performance control layers are installed properly and fully tested in an appropriate manner.

2.4_ Owner's Project Requirements: The Value of Goal Setting

We all know that setting goals is important, but we often don't realize how essential they are. Goals help motivate us to develop strategies that enable us to perform at the required goal level. Setting goals helps trigger new behaviors, helps guide your focus and helps you sustain momentum. In the end, you can't manage what you don't measure and you can't improve upon something that you don't properly manage. Setting goals can help you do all of that and more.

Dr. Edward Locke and Dr. Gary Latham, co-authors of the 1990 book, "A Theory of Goal Setting & Task Performance," are leaders in goal-setting theory. Locke and Latham established five goal-setting principles that can help improve your chances of success:

Clarity » Challenge » Commitment » Feedback » Task Complexity

Clarity is important when it comes to goals. Setting goals that are clear and specific eliminate the confusion that occurs when a goal is set in a more generic manner.

Challenging goals stretch your mind and cause you to think bigger. This helps you accomplish more. Each success you achieve helps you build a winning mindset.

Commitment is also important. If you don't commit to your goal with everything you have it is less likely you will achieve it.

Feedback helps you know what you are doing right and how you are doing. This allows you to adjust your expectations and your plan of action going forward.

Task Complexity is the final factor. It's important to set goals that are aligned with the goal's complexity.

The objective of any project is to provide a facility that fulfills the functional and performance requirements of the owner, occupants, and operators. To attain this objective, it is necessary to establish and document Owner Project Requirements (OPR), forming the basis from which all design, construction, acceptance and operational decisions are made. Figure 2.5 provides a framework for the types of requirements that should be considered.

2.0_UNIVERSAL DESIGN, CONSTRUCTION, AND OPERATIONAL PHASE CONSIDERATIONS

FIGURE 2.5: OWNER'S PROJECT REQUIREMENTS FRAMEWORK

Accessibility	Architectural Barriers Act Accessibility Standard (ABAAS)	Indoor Environment	Including hygrothermal, air temperature, humidity, condensation, indoor air quality and weather resistance
Acoustics	Control of internal and external noise and intelligibility of sound	Installation evaluation, testing requirements, and sampling procedures	Evaluation, testing, integrated system design and testing and sampling criteria quantity identified.
Comfort	Identify and document those comfort problems that have caused complaints in the past and which will be voided in this facility (i.e. glare, uneven air distribution, etc.)	Light	Including natural and artificial (i.e. electric, solar, etc.) illumination
Communications	Capacity to provide inter- and intra-telecommunications throughout the facility	Maintenance Requirements	Varied level of knowledge of maintenance staff and the expected complexity of the proposed systems, maintainability, access and operational performance requirements.
Constructability	Feasibility of transportation to site, erection of components and assemblies, and health and safety during construction. Consider contractor means and methods and identifies risk in successful execution.	Security	Protection against intrusion (physical, thermal, sound, etc.) and vandalism and chemical/biological/radiological threats
Design Coordination	Resolve all technical problems thoroughly and across disciplines to ensure durability and optimize facility life cycle performance.	Site Development	Systematic process of verifying that the dynamic systems built beyond a building's skin, perform in accordance with design intent and the property owner's operational needs including stormwater management, site utilities, irrigation, filtration, water harvesting systems and dynamic site security systems. (Background report for reviewers on this subject can be found at: https://www.gsa.gov/real-estate/design-construction/landscape-architecture/landscape-analytics-and-commissioning)
Design Excellence	Concept development DE peer review process and incorporating peer guidance and adherence to approved design concept as design progresses	Standards Integration	Integration of approved Federal, State and local as well as GSA and Customer Agency standards and requirements
Durability	Retention of performance over required service life	Structural Safety	Resistance to static and dynamic forces, impact and progressive collapse
Energy	Goals for energy efficiency (to the extent they are not called out in the Green Building Concepts)	Sustainability	Sustainability concepts including LEED certification goals
Fire Protection & Life Safety	Fire protection and life safety systems. This includes active and passive fire protection and life safety systems and their interconnection with other building systems.	Training	Training requirements for the Owner's staff
Flexibility	For future facility changes and expansions		
Health & Hygiene	Protection from contamination from waste water, garbage and other wastes, emissions and toxic materials		

Source: Adapted from "GSA Commissioning Guide," September 2020
https://www.gsa.gov/cdnstatic/GSA_Commissioning%20Guide_Sept_2020_Final_0.pdf

2.0_ UNIVERSAL DESIGN, CONSTRUCTION, AND OPERATIONAL PHASE CONSIDERATIONS

Obtaining the information and criteria for the Owner Project Requirements (OPR) necessitates input from all key facility users and operators.

The OPR should be expected to evolve throughout each project stage. As decisions are made throughout the planning, design, and construction phases, the OPR should be updated for use in validating, at the end of construction, that a facility fulfills the desired functional and performance requirements. It also serves as the primary tool for benchmarking success and should ultimately become part of the operations phase documentation.

OPR development is ideally led by a project ownership stakeholder in order to truly capture the owner's aspirational goals, especially when these goals challenge existing design and construction paradigms. However, this task is often assigned to an owner's representative such as the project's Commissioning Agent. The OPR should ideally be completed before the design and construction team are hired.

2.4.1_ TRANSITION FROM A ZERO NET ENERGY TO A ZERO NET CARBON MINDSET

One of the paradigm shifts occurring with the developing focus on carbon is the transition from energy conservation to carbon emissions reduction goals. What will be seen throughout this practice guide is that design approaches for energy conservation are incomplete for addressing carbon emissions reduction strategies.

It is obvious that using less energy also reduces carbon. But, in a world where project cost budgets are finite, the lowest energy use strategy may not be achievable while the lowest carbon footprint strategy might be. In the extreme, imagine that every building project was all-electric, and one could include, in every project, enough onsite solar electricity generation to offset 100% of site energy use. Presto! Operationally, such a building is carbon neutral, regardless of overall energy consumption. Operational

carbon neutrality could also be achieved if 100% of the grid purchased energy for this facility was from renewable energy sources.

With the cost of solar photo-voltaic (PV) systems nationally in the \$2.50 to \$3.00 range per installed watt for residential systems and \$1.50 to \$2.50 per installed watt for larger commercial systems, solar electricity can be produced at a lower cost onsite than utility company prices in many places in the U.S.^{5,6} Also, many owners have access to electricity from renewable energy sources without any investment of their own money. Buying solar electricity through a "Power Purchase Agreement" allows investors to essentially build an onsite utility source at their own expense, sell the electricity to the building owner/occupant, and make a healthy return on their investment in the process. Community choice aggregators and many utility companies also offer their customers access to 100% renewable energy from the local utility grid.

Thus, a real path to operational carbon neutrality is all-electric building design and operation, served by a 100% renewable energy source. This concept is the underpinning of the movement towards all-electric building design. In fact, State commitments to renewable energy have consistently grown since the first Renewable Portfolio Standard (RPS) was adopted by Iowa in 1983. Since then, more than half of U.S. states have established renewable energy targets. Thirty states, Washington, D.C., and three territories have adopted an RPS, while seven states and one territory have set renewable energy goals (see Figure 2.6). Although most state targets are between 10% and 45%, fourteen states — California, Colorado, Hawaii, Maine, Maryland, Massachusetts, Nevada, New Mexico, New Jersey, New York, Oregon, Vermont, Virginia, Washington, as well as Washington, D.C. Puerto Rico and the Virgin Islands — have requirements of 50% or greater. Guam also has a voluntary RPS goal of 50% by 2035 and 100% by 2045. In 2019, natural gas was the largest source of electricity in 20 states, while wind emerged as a leader in Iowa and Kansas. Coal remained the primary power source in only 15 states — about half as many as two decades ago.

⁵ See <https://www.consumeraffairs.com/solar-energy/how-much-do-solar-panels-cost.html> for average cost per State.

⁶ <https://cleantechnica.com/2021/02/13/charts-a-decade-of-cost-declines-for-pv-systems/>



2.0_ UNIVERSAL DESIGN, CONSTRUCTION, AND OPERATIONAL PHASE CONSIDERATIONS

With nine States committed to 100% GHG neutral power generation on or before 2050, the future of an electrical grid powered by 100% renewable energy is still not a certainty, so all-electric building projects would be well-advised to estimate a project's lifetime carbon emissions and develop and implement strategies to eliminate their projects' carbon debt during the project's lifetime.

FIGURE 2.6: RENEWABLE PORTFOLIO STANDARDS OR VOLUNTARY TARGETS

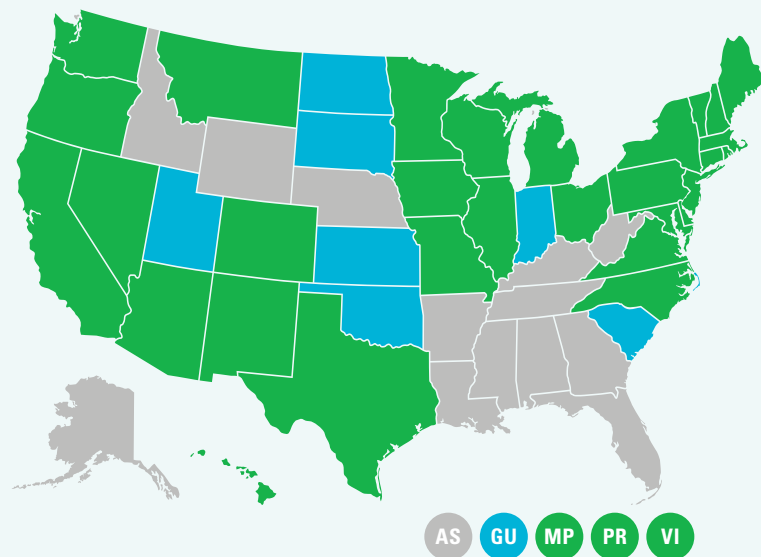

- States and territories with Renewable Portfolio Standards
- States and territories with a voluntary renewable energy standard or target
- States and territories with no standard or target

Source: <https://www.ncsl.org/research/energy/renewable-portfolio-standards.aspx>

As buildings are designed to consume less energy, and as the energy consumed becomes less carbon intensive, neglecting offsite carbon emissions associated with construction becomes increasingly problematic. The offsite emissions associated with producing materials, as well as emissions associated with transporting and installing materials, make up the “Embodied Carbon” of a building project. Ignoring embodied carbon results in an incomplete understanding of project-related carbon emissions. It also ignores areas where low cost carbon reductions may be achievable. After eliminating operational carbon, the reduction of embodied carbon becomes an essential strategy for achieving drastic reductions in overall carbon emissions associated with buildings, which will be key to a successful response to the climate change impacts of the built environment.

2.4.2_ ALL-ELECTRIC BUILDING DESIGN

As stated above, operational carbon neutrality can be achieved through all-electric building design, and operations served by 100% renewable energy sources. It is this fact that has, by December of 2021, led 54 California jurisdictions, representing over 11% of the State's population, to adopt building codes and ordinances to reduce their reliance on gas. The effort has spread to other parts of the country. The Massachusetts town of Brookline passed a prohibition on new gas connections, and municipalities near it are poised to do the same. Major cities, including Seattle, are in various stages of considering all-electric building legislation.

This movement to legislate all-electric construction — primarily focused at this time on new construction — comes from the recognition that the level of carbon emissions reduction required to avoid the worst impacts of climate change will be entirely unachievable if we continue to build buildings that are not operationally carbon-neutral. Every new building built with the onsite use of carbon-emitting fuels is just a future existing building that needs to be retrofitted. And future retrofit for all-electric operation is expensive, not cost effective, difficult to legislate, and represents the building sector's largest challenge when it comes to climate action.

Thus, when setting project goals, this is one of the most important decisions that an owner can make with respect to the future of their carbon footprint and our collective ability to combat climate change. OPR's should be clear about what is expected with respect to the onsite use of any fossil fuels. If these are not outright excluded from a project, owners should give extremely serious consideration to requiring their designers to enable future conversion to all-electric operation in a cost-effective manner. Such designs would include measures like increasing the capacity of electrical systems, allocating space for future equipment, and installing PV-ready infrastructure.

2.5_Using Building Performance Modeling as a Design Guidance Tool

Building performance modeling has traditionally been focused on energy modeling and has been used to predict the difference in energy use between alternate building and systems design strategies. It has also become common to use energy modeling in demonstrating compliance with Energy Code requirements. In the context of high-performance buildings overall, energy use is only one consideration, and energy models only tell one chapter of the story about a building's performance. Comfort, good access to daylight, thermal performance of building assemblies, and operational and embodied carbon footprint are all aspects of a building's full story that can be told through modeling. And, with a full complement of modeling analysis, truly optimal decisions can be made that allow for performance metrics to be prioritized and trade-offs recognized during building design. When done right, and given enough time and resources, modeling can be one of the most important steps in the successful delivery of all-electric building designs.

2.5.1_OPERATIONAL CARBON

2.5.1.1_Energy Efficiency is Still Important

For decades, the design and construction industry has focused on energy use reduction, whether due to Code compliance or for maximizing the financial return on infrastructure investments. The premise of this practice guide's approach for all-electric buildings is that all site fossil-fuel use is eliminated from a project, and source energy is from a grid fed by 100% renewable energy. Thus, energy use reduction would seem to have very little to do with emissions reductions. However, while minimizing the carbon emissions related to building design and construction is fundamentally a different focus, the synergies between carbon emissions and energy use reductions are significant. The biggest benefits from energy efficiency in an all-electric building come from:

1. Reduction of the electrical service size: electrical infrastructure cost (switchboards, utility connection charges, etc.) tends to vary in a fairly linear fashion with peak load until building ampacity gets very large.
2. Reduction of the peak capacity of HVAC systems: this can be especially beneficial if thermal energy is the primary method for distributing energy, as heat pumps can often occupy a lot more physical space than their conventional equipment counterparts.
3. Reduction in the size of onsite photovoltaic systems required to minimize carbon emissions related to grid-purchased energy.
4. Code compliance: States that have adopted ASHRAE 90.1 use energy cost as the compliance metric. So, saving energy reduces cost, and hence can help with the other Code-compliance challenges that are present for all-electric buildings (see the Codes & Policy Volume for more discussion of these issues).

2.0_ UNIVERSAL DESIGN, CONSTRUCTION, AND OPERATIONAL PHASE CONSIDERATIONS

Investing in efficiency first can help reduce or even eliminate the cost premiums of all-electric building designs and ensure that projects comply with their local Energy Code requirements. Traditional energy modeling has been extremely effective at evaluating the energy use reduction potential of various energy conservation measures. However, energy efficiency as the sole focus of advanced building design will not accomplish the urgent goals behind decarbonization of the built environment.

2.5.1.2_Building Enclosure Performance

Most successful high-performance buildings have placed significant emphasis on the role of the building enclosure in achieving their performance goals. This is even more important with all-electric building designs: the design, procurement, and construction of the building enclosure becomes an increasingly important system to develop, purchase, and construct for delivering a cost-effective all-electric, low operational, and embodied carbon building design.

Since the same systems (e.g. heat pumps) often serve both cooling and heating loads, load reduction strategies that impact the load during all seasons become more important in order to effectively reduce installed system costs. For example, heating with heat pumps can be a greater challenge in cold climates, where meeting heating loads will define the peak capacity required; thus, the reduction or elimination of perimeter heating using “super-insulated”⁷ building enclosures can have significant cost and design benefits.

Limited modeling of enclosure construction is standard in all energy modeling. However, there can be value in detailed enclosure specific modeling early in the design phase to define achievable and specific enclosure performance goals. Parametric modeling, heat transfer modeling, and comfort modeling are all approaches to enclosure performance evaluation that can contribute significantly to the selection of an enclosure that is ultimately incorporated into an energy model.

⁷ See <https://en.wikipedia.org/wiki/Superinsulation>.

⁸ See Steven J. Emmerich, Timothy P. McDowell, W Anis. “Investigation of the Impact of Commercial Building Envelope Airtightness on HVAC Energy Use.” June 1, 2005 <https://www.nist.gov/publications/investigation-impact-commercial-building-envelope-airtightness-hvac-energy-use-0>

Early, enclosure specific parametric models should include and document key assumptions regarding thermal breaks, continuity, etc. as well as specific wall material options (a level of detail that is not currently included in industry standard energy modeling services). It should be recognized that the type of advanced enclosure modeling discussed above is an area of expertise that is distinct from building energy modeling and requires that consultants who have this specific expertise be included on the design team.

Detailed definition of the enclosure construction and performance requirements can also help avoid performance and compliance issues when alternate materials or methods are considered during the construction phase. If designs are based on an enclosure that meets superior performance criteria, then it becomes extremely valuable to ensure that enclosure construction is thoroughly detailed and specified, and that quality control during construction is maintained.

2.5.1.2.1_THERMAL BRIDGING

Designing enclosure systems to avoid thermal bridging includes the use of continuous external insulation and providing thermal continuity at interfaces. Software tools such as THERM (free download at <https://windows.lbl.gov/software/therm>) can facilitate detailed evaluation of thermal discontinuities.

2.5.1.2.2_INFILTRATION

Assumptions about infiltration are often given very little consideration in energy models, yet studies have shown that the average building enclosure is much less airtight than often thought.⁸ A poorly installed air barrier can offset all efforts at improving thermal insulation and mitigating thermal breaks, rendering the insulation essentially ineffective. Based on studies of existing buildings done in the 1970s and 1980s, the ASHRAE 1997 Fundamentals Handbook suggests that commercial office buildings were “leakier than expected.” It is likely that construction practices have improved somewhat, but experience still suggests that air-tight enclosure construction does not happen without both intention and attention.



2.0 UNIVERSAL DESIGN, CONSTRUCTION, AND OPERATIONAL PHASE CONSIDERATIONS

In terms of airtightness, the Passive House Standard⁹ is considered best practice. While it may not be applicable to every project, it does shed light on what level of airtightness one might strive for to minimize heating and cooling loads related to air infiltration. A project can also gain additional benefits from air-tight construction, such as improved comfort and reduced energy consumption.

2.5.1.3 Energy Modeling, Carbon Emissions and Life Cycle Cost

In spite of the shift towards renewables over the past decade, Energy Codes continue to compare a proposed all-electric building against a “standard design” that is, in most cases, fueled by a combination of electricity and natural gas. Simulations for annual building energy cost measured against a natural gas baseline can mask the benefits of saving low-cost/high-carbon fuels (e.g., natural gas) rather than electricity, which in most states is more expensive per BTU than natural gas. When evaluating the performance of an all-electric building with cost as the metric (typical in all States that use ASHRAE 90.1 as their Energy Code), the all-electric building design can be unfairly penalized in areas with high electricity cost, even though the carbon content of the electricity may be favorable for achieving emissions reduction goals. Energy Use Intensity (EUI) is a common metric used to evaluate high-performance buildings, but this metric fails to account for the carbon emissions impacts of design choices.

California has adopted a different metric — BTU per square foot per year, modified hourly based on a Time Dependent Valuation (TDV) multiplier (for more discussion of this see the Volume on Codes and Policy). However, neither cost nor TDV-adjusted energy use fully account for the carbon content of a fuel choice, and thus can inadvertently steer design choices away from all-electric building design. Thus, alternate metrics can be extremely useful in evaluating the performance of all-electric building designs.

2.5.1.3.1 CARBON EMISSIONS METRICS

If carbon neutrality is a key goal of your project, then comparing new construction to existing building reuse should investigate both first cost as well as short and long term carbon emissions reductions.

One can also look at a ratio between first cost (or life cycle cost) and avoided carbon emissions to arrive at a metric (\$ per pound of avoided CO₂e emissions) that can be used to guide decision-making; this metric can help owners decide on how to maximize their investments in carbon emissions reduction.

Accounting for the carbon emissions related to grid-purchased energy can also be an important consideration in evaluating alternative design strategies. Carbon-related metrics for grid-supplied energy continue to evolve away from pounds of carbon per kilowatt hour based on the national average fuel mix to metrics based on regional grid averages. Data on hourly carbon content of grid sources in real time are becoming widely available, and can be used — instead of utility costs — to evaluate the performance of designs as well as manage system operations (for example, with loads that can be deployed based on marginal emissions on the grid, or with designs incorporating microgrid¹⁰ control systems).

Data sets for simulation tools — to the extent that they are available — use predicted carbon profiles to evaluate the annual carbon emissions of proposed designs. This only allows project teams to make design decisions based on minimizing pro-forma carbon emissions on hourly and seasonal bases. Nevertheless, meeting carbon reduction goals based on pro-forma hourly metrics still encourages the use of load shifting technologies such as thermal storage and energy storage systems as well as load shifting and deployable load controls in building design. These technologies are critical in the short term to obtaining significant emissions reductions and to ultimately achieving zero emissions.

⁹ <https://www.phius.org/what-is-passive-building/passive-house-principles>

¹⁰ See <https://www.microgridknowledge.com/about-microgrids/article/11429017/what-is-a-microgrid>.



2.0 _ UNIVERSAL DESIGN, CONSTRUCTION, AND OPERATIONAL PHASE CONSIDERATIONS

2.5.1.3.2 _ CARBON EMISSIONS EQUIVALENT

While the burning of fossil fuels accounts for the vast majority of human-caused greenhouse gas emissions in the U.S. (in 2018, about 93% of total U.S. anthropogenic CO₂ emissions¹¹), it only accounted for about 75% of total U.S. anthropogenic greenhouse gas (GHG) emissions in that same year. Other GHGs relevant to the building sector include methane and hydrofluorocarbons (HFCs).

Methane leakage from utility company natural gas distribution pipelines is a growing concern (natural gas is roughly 86 times more potent than CO₂ as a GHG over 20 years). Over 50% of the main pipelines in local natural gas distribution systems in the U.S. are more than 30 years old, and over 20% are more than 60 years old.¹² All told, based on the results of the natural gas industry's own study, the U.S. oil and gas industry is leaking 13 million metric tons of methane each year, which means the methane leak rate is 2.3 percent of total production. This leakage rate undermines the benefits of replacing many other “dirty” fuels (such as coal) with natural gas. And, this makes methane leakage almost 20% of all US GHG emissions. Avoiding the astronomical cost of upgrading the natural gas infrastructure is another benefit to universal building electrification.

HFCs are used as refrigerants in almost all electric-driven cooling systems and many modern electric-driven heating systems. Many of the HFCs used are potent GHGs (some thousands of times more potent than CO₂ as shown in Figure 2.7). Preventing the leakage of refrigerants is a fundamental goal of good equipment design, service, and maintenance. However, there has been an increasing focus both on leakage reduction due to the financial and environmental costs of leakage and on refrigerant selection as a method of reducing the environmental impact of refrigerant leakage.

When accounting for the climate impacts of system designs, all project-related emissions that have global warming impacts should be considered. To this end, the metric of “carbon dioxide equivalent” was developed.

¹¹ From U.S. Energy Information Administration data.

¹² From “A National Estimate of Methane Leakage from Pipeline Mains in Natural Gas Local Distribution Systems”, Zachary D. Weller, Steven P. Hamburg, and Joseph C. von Fischer, *Environ. Sci. Technol* 2020 (<https://pubs.acs.org/doi/10.1021/acs.est.0c00437>)

A carbon dioxide equivalent (or CO₂ equivalent, abbreviated as CO₂e) is a metric used to compare the emissions from various greenhouse gases on the basis of their global-warming potential (GWP), by converting amounts of other gases to the equivalent amount of carbon dioxide with the same global warming potential.

2.5.1.3.3 _ LIFE CYCLE COSTS AND CARBON

Financial decision-making that focuses on life cycle cost, rather than first cost, can support decarbonization efforts. Thus, it is important to understand any given owner's perspective on operations, maintenance, and replacement costs as part of making the case for specific decarbonization strategies.

Also, finding ways to factor in financial metrics related to carbon can be effective at promoting the adoption of decarbonization strategies. Large carbon emitters in California are already subject to the costs of the State's Cap-and-Trade Program. New York and ten other Northeastern and Mid-Atlantic States established the Regional Greenhouse Gas Initiative (RGGI), which subjects electric generation facilities to cap-and-trade rules similar to California's program. So, for emitters that fall under these programs, there are real costs associated with their carbon emissions. For others, planning for the day when carbon pollution has a regulatory cost can be a reasonable risk management need, whether these pollution costs are borne by owners directly, as in California and New York, or for when they become a larger component of utility costs that will affect all utility customers.

Until the cost of carbon pollution is reflected in the rate tariffs for fuels purchased for building operations, utility rates will not be an effective market driver for decarbonization. In the interim, one way to factor in the future cost of carbon can be through using artificial utility tariffs that correlate marginal emissions rates to cost. This artificial rate structure can then be easily used in the design team's “energy” modeling software to evaluate carbon reduction strategies; in this approach, minimizing utility costs will be directly correlated with minimizing carbon emissions (refer to Figure 2.9).



2.0_UNIVERSAL DESIGN, CONSTRUCTION, AND OPERATIONAL PHASE CONSIDERATIONS

FIGURE 2.7: GLOBAL WARMING POTENTIAL OF COMMON REFRIGERANTS

Refrigerant Name	Trade or Common Name	CAS Name	Global Warming Potential (GWP) ^[3]
R-717	Ammonia	Ammonia	0
R-1224yd(Z)	AMOLEATM 1224yd	(Z)-1-Chloro-2,3,3,3-Tetrafluoropropane	1
R-744 ^[1]	CO ₂	Carbon dioxide	1
R-1234zd(E)	Solstice zd	Trans-1-chloro-3,3,3-trifluoropropene	1
R-514A	Opteon XP30	HFO-1336mzzZ/trans-1,2-dichloroethylene (t-DCE) (74.7/25.3)	2
R-1270	Propylene	Propene, Propylene, Methyl Ethylene	2
R-290	Propane	Propane	4
R-1234yf ^[2]	HFO-1234yf	2,3,3,3-Tetrafluoropropene	4
R-1150	Ethene	Ethene, Ethylene	4
R-600a	Isobutane	Isobutane	5
R-1234ze(E)	Solstice ze	1,3,3,3-Tetrafluoropropene	6
R-170	Ethane	Ethane	6
R-601	Pentane	Pentane	11

Refrigerant Name	Trade or Common Name	CAS Name	Global Warming Potential (GWP) ^[3]
R-123 ^[4]	HCFC-123	2,2-Dichloro-1,1,1-trifluoroethane	77
R-152a	HFC-152a	1,1-Difluoroethane	124
R-32	HFC-32	Difluoromethane	675
R-401A	MP39	R-22/R-152a/R-124 (53/13/34)	1182
R-134a ^[7]	HFC-134a	1,1,1,2-Tetrafluoroethane	1430
R-407C	--	R-32/R-125/R-134a (23/25/52)	1774
R-22 ^[5]	HCFC-22, Freon	Chlorodifluoromethane	810
R-410A	Puron, AZ-20	R-32/R-125 (50/50)	2088
R-407A	KLEA 60	R-32/R-125/R-134a (20/40/40)	2107
R-125	HFC-125	Pentafluoroethane	3500
R-404A	HP-62	R-125/R-143a/R-134a (44/52/4)	3922
R-11 ^[6]	CFC-11	Trichlorofluoromethane	4750
R-12 ^[6]	CFC-12	Dichlorodifluoromethane	10900

[1] As of May, 2021, CO₂ heat pumps are available from Sanden, Mayekawa, Watts, and Mitsubishi. Other manufacturers have CO₂ heat pumps under development (e.g. Nyle) due to growing market interest/demand.

[2] Proposed HFO replacement for R-134a (which is a popular high-GWP HFC that is being phased out under the EPA rules adopted in 2016). R-134a will no longer be available for new chillers starting on January 1, 2024.

[3] GWPs listed are IPCC AR4 (2007), 100-year GWPs.

[4] R-123 was phased out for new HVAC equipment on Jan. 1, 2020; it will continue to be produced for servicing equipment until 2030.

[5] Starting in 2020, R-22 was no longer produced or imported. After 2020, only recovered, recycled, or reclaimed supplies of R-22 will be available.

[6] R-11 and R-12 were completely banned from production in 1996 under the Montreal Protocol due to their ozone depletion characteristics.

[7] Refrigerants in red text are the most ubiquitous currently in use in new HVAC equipment. R-717 (CO₂) is growing in popularity, albeit equipment options are currently limited.



2.0_UNIVERSAL DESIGN, CONSTRUCTION, AND OPERATIONAL PHASE CONSIDERATIONS

Tools to assist with implementation of this methodology are currently being developed to be more accessible to the design community; robust data sets for modeling marginal emission rates in different utility sectors are available through non-profit entities like Watttime and by the National Renewable Energy Laboratory (NREL). The map below from Watttime (Figure 2.8)

represents the electrical sub-regions in 2020 that track hourly marginal emission factors.

Refer to <https://www.watttime.org/explorer/#3/41.23/-97.64> for real-time, location-specific information on marginal emissions rate from the grid in your area.

FIGURE 2.8: GRID EMISSIONS INTENSITY BY ELECTRIC GRID

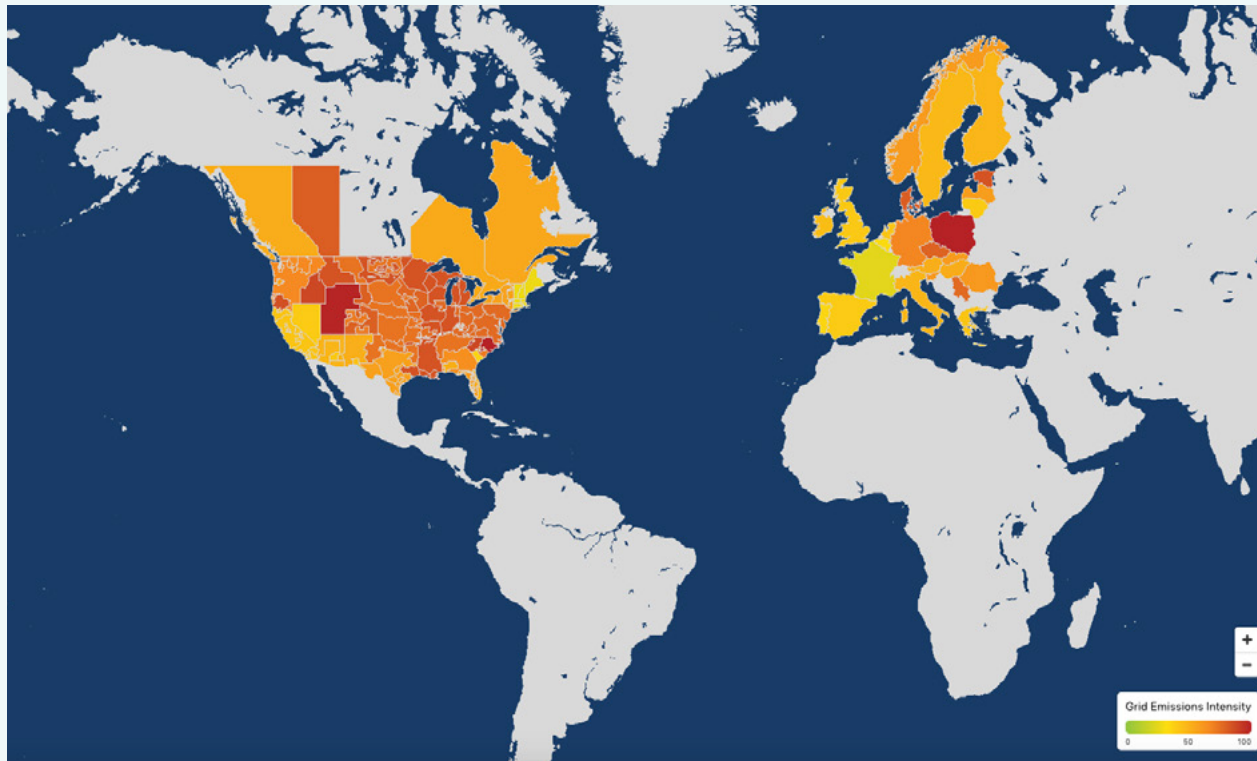

Grid emissions intensity on a scale of 1 – 100 relative to other electric grids. In other words, lower on scale is the cleanest any grid gets and higher on the scale is the dirtiest any grid gets.

Source: Watt Time
<https://www.watttime.org/explorer/#3/41.23/-97.64>

2.0_UNIVERSAL DESIGN, CONSTRUCTION, AND OPERATIONAL PHASE CONSIDERATIONS

FIGURE 2.9: UTILITY COSTS ARE NOT ALIGNED WITH GRID EMISSIONS

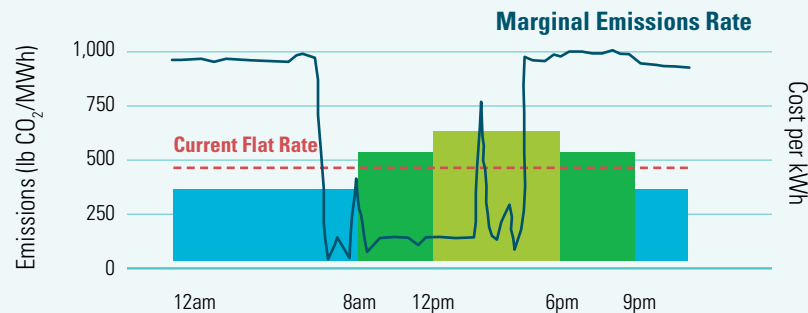

Example above is what it looks like to have a tariff schedule that does not align with grid emissions

■ Off-peak ■ Partial-peak ■ On-peak

Source: Developed by Steve Guttman, Guttman & Blaevoet

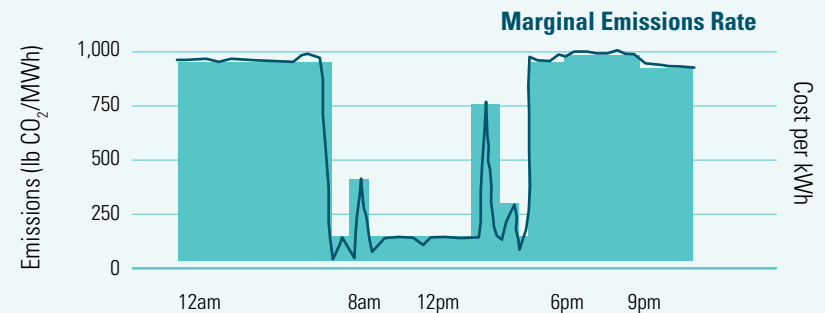

Example above is what it looks like to have a tariff schedule that perfectly aligns with grid emissions

■ Rate varies continuously throughout the day based on current marginal emissions rate

Access to the regional marginal emissions factors allows designers to fully understand electrification decisions based on the carbon emissions reduction potential versus operational costs. Since each subregion has different source mixes, grid emissions profiles can be significantly different on an hourly basis. California's solar access and heavy reliance on natural gas and nuclear power create a very different emission profile than Eastern Colorado or West Texas, which have higher uses of coal and large amounts of wind power (see Figure 2.10).

These tools allow future cost risks to be incorporated into a life cycle cost analysis or a risk management evaluation that looks at the sensitivity of financial performance metrics on a range of future emissions avoidance scenarios.

FIGURE 2.10: REAL TIME AND FORECASTED MARGINAL EMISSION RATE DATA IS AVAILABLE

SPP North Texas

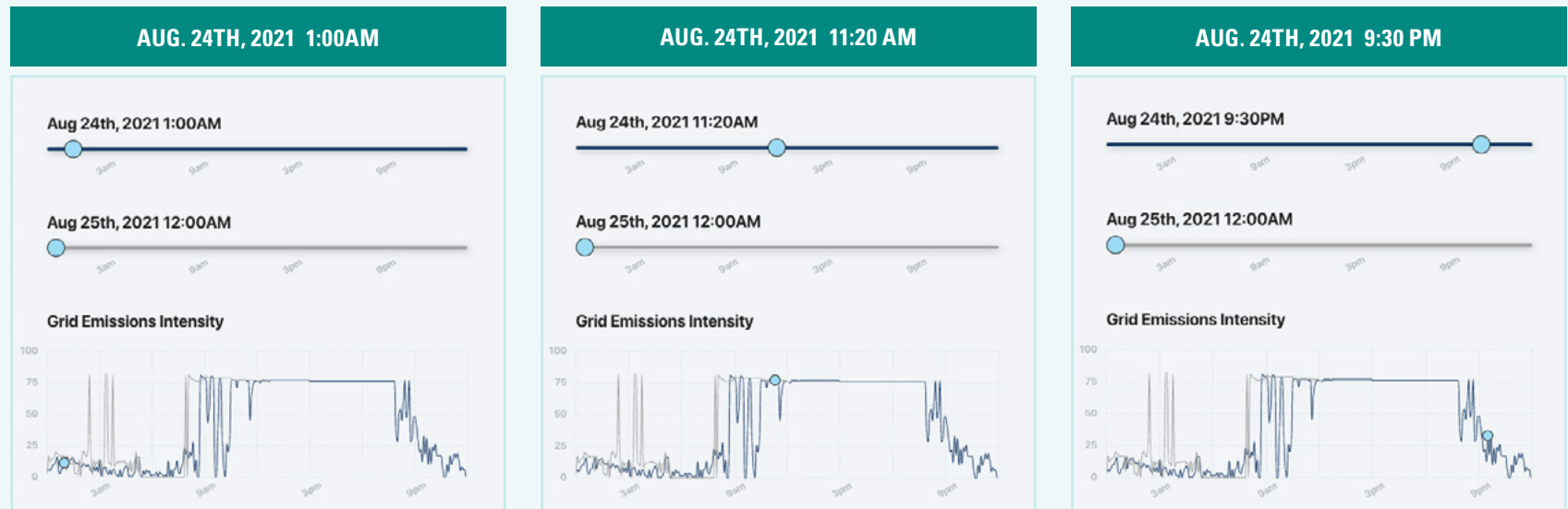

Grid Emissions Intensity = 17

Grid Emissions Intensity = 77

Grid Emissions Intensity = 33

Grid emissions intensity on a scale of 1 – 100 relative to other electric grids. In other words, lower on scale is the cleanest any grid gets and higher on the scale is the dirtiest any grid gets.

Source: Watt Time | <https://www.watttime.org/explorer/#3/41.23/-97.64>

2.0_UNIVERSAL DESIGN, CONSTRUCTION, AND OPERATIONAL PHASE CONSIDERATIONS

FIGURE 2.11: PROJECTIONS OF CALIFORNIA GAS DEMAND AND NATURAL GAS PRICES IN VARIOUS GHG EMISSIONS REDUCTION SCENARIOS

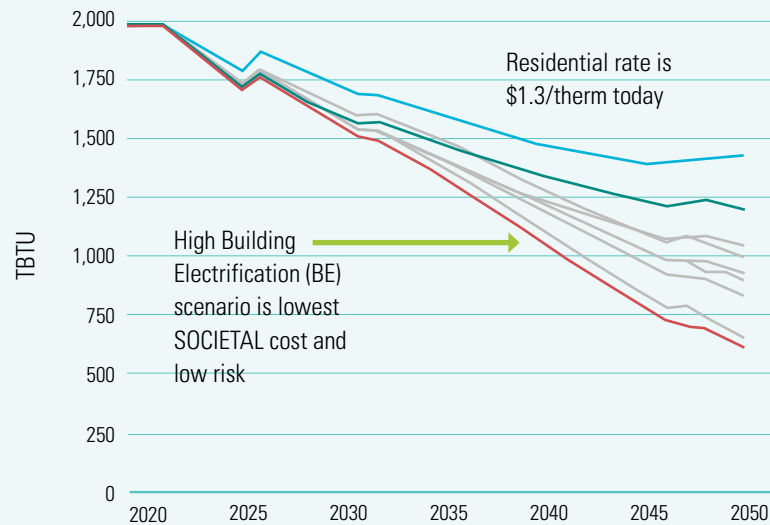

- Current Policy Reference: \$2.60/therm in 2050, 13 million gas customers remain
- No Building Electrification with Synthetic Natural Gas (SNG): \$4-5/therm in 2050, 13 million gas customers remain
- High Building Electrification: \$18/therm in 2050 with no gas transition strategy, 2 million gas customers remain

Notes: Rates are for residential customers; all results shown in 2018 (real). The analytics did not include customer price sensitivity feedback loops. Including price sensitivity modeling might lower the number of customers remaining on the system in 2050.

Source: Gridworks

Life cycle cost analyses also need to take a realistic look at the sensitivity of life cycle costs to the potential futures of natural gas prices in high-electrification scenarios. In an electrified future, a reduced ratepayer base will need to cover the cost of the natural gas distribution system maintenance, upgrade, and other operating costs. Studies by Gridworks and E3 performed for the California Energy Commission¹³ showed costs per therm increasing from \$1.30 in 2020 to as high as \$18 per therm in 2050, based on a “high building electrification scenario,” and as low as \$4 per therm if an aggressive transition strategy is put in place (see Figure 2.11). The impacts of these possible escalations in future utility costs should be factored into any meaningful life cycle cost risk analysis.

2.5.2_EMBODIED CARBON

As discussed earlier, buildings produce greenhouse gases at every stage of the building lifecycle from extraction of virgin materials to disposition of construction waste. So as the electricity supply transitions to a greater percentage of renewable sources and operational carbon emissions are reduced, the pre-occupancy stage of a building’s life begins to matter more as the contribution of carbon to the atmosphere “embodied” in the construction becomes a larger portion of the impact of a building’s entire life span. It stands to reason, therefore, that the amount of construction required to meet the needs of projected population growth over the coming decades increases the urgency of addressing embodied carbon.

According to the non-profit organization Architecture 2030, “The embodied carbon emissions of building products and construction represent a significant portion of global emissions: concrete, iron, and steel alone produce ~9% of annual global GHG emissions; embodied carbon emissions from the building sector produce 11% of annual global GHG emissions. Embodied carbon will be responsible for almost half of total new construction emissions between now and 2050.”¹⁴

¹³ “California’s Gas System in Transition: Equitable, Affordable, Decarbonized and Smaller,” pub. by Gridworks, and “Deep Decarbonization in a High Renewables Future: Updated Results from the California PATHWAYS Model” pub. by the CEC on June 13, 2018.

¹⁴ See <https://architecture2030.org/new-buildings-embodied/>.



Volume 6 of this practice guide is devoted to reducing the embodied carbon in buildings. This Volume identifies reduction opportunities. Volume 6 recommends addressing high volume and carbon intensive building elements first:

- a. Concrete** accounts for more carbon emissions than any other material on the planet. Pretty much all buildings use concrete, if not in the structural frame and envelope, then in the foundations. Concrete usually accounts for more carbon emissions than any other material and often more than all other materials combined. For wood framed buildings, concrete can account for 75% of the total weight of the building.
 - i. What you can do:** Work with your structural engineer to minimize the amount of concrete on your project and specify low carbon concrete mixes that replace the Portland cement with supplementary cementitious materials such as fly ash and slag.
- b. Steel:** second only to concrete in global carbon emissions, not all steel is created equal. Steel from Electric Arc Furnaces (EAF) has high recycled content and a much lower carbon footprint than steel from Basic Oxygen Furnaces (BOF) that use more virgin ore and burn coal and coke. EAF products include structural steel shapes, reinforcing bars, flats, angles, rods and pipes. BOF products typically include sheet steel and metal studs.
 - i. What you can do:** Use steel sparingly and efficiently and select products produced in EAF's in areas with clean power grids.

Additional strategies for reducing embodied carbon include:

1. Quantifying the embodied carbon in your project
2. Familiarizing your team with high-impact materials and systems
3. Sourcing from lower-impact manufacturers
4. Optimizing the use of materials
5. Reusing materials
6. Using more biobased and other carbon-sequestering materials

2.6 _ Design Approaches

2.6.1 _ HIGH PERFORMANCE ENVELOPES

While entire books have been written about high performance enclosures,¹⁵ this practice guide focuses on a few key issues that can be the difference, between good and great performance.

The lack of continuity at the interfaces between enclosure systems and performance enhancing features (e.g. insulating materials, air-barriers, etc.) can seriously degrade overall enclosure performance. Rigorous review of design documentation for materials, layers, and interfaces can help clarify and define expectations for a contractor's installation. It is best if these reviews identify the detailing needed as well as the coordination of the interfaces between materials furnished by different trade partners.

Two aspects of enclosure design that are often overlooked but play a critical role in high performance enclosure design are thermal bridging and air barriers.

2.6.1.1 _ Thermal Bridging

Heat will transfer through a building's thermal envelope at different rates depending on the materials present throughout the envelope. Heat transfer will be greater at "thermal bridge" locations than where insulation exists because there is less thermal resistance.

"Super-insulated" enclosures (typically, walls with an effective R-value of 40 or greater and roofs with an effective R-value of 60 or greater) rely on strategies that incorporate thicker construction to accommodate insulation with increased R-value as well as a focus on the reduction of thermal bridging.

¹⁵ For example, see <https://www.buildingscience.com/bookstore/books/high-performance-enclosures>.

2.0 _ UNIVERSAL DESIGN, CONSTRUCTION, AND OPERATIONAL PHASE CONSIDERATIONS

Designing enclosure systems to avoid thermal bridging includes the use of continuous external insulation and providing thermal continuity at interfaces. Rigorous design review for thermal continuity should be performed since poor continuity affects a significantly larger area of the wall's thermal performance than merely the line of the discontinuity, resulting in a more significant reduction in average overall thermal performance than would be intuitively anticipated.

There are several methods that have been proven to reduce or eliminate thermal bridging depending on the cause, location, and construction type. The objective of these methods is to either create a thermal break where a building component would otherwise span from exterior to interior or to reduce the number of building components spanning from exterior to interior.

Strategies include:

- » A continuous thermal insulation layer in the thermal envelope, such as with rigid foam board insulation
- » Lapping of insulation where direct continuity is not possible
- » Double and staggered wall assemblies
- » Structural Insulated Panels (SIPs) and Insulating Concrete Forms (ICFs)
- » Reducing framing factor by eliminating unnecessary framing members
- » Raised heel trusses at wall-to-roof junctions or other construction features that allow for increased roof insulation depth without compression
- » Quality insulation installation without voids or compressed insulation

- » Installing double or triple pane windows with gas filler and low-emissivity coating
- » Installing windows with thermally broken frames made from low conductivity material

Details on many of these strategies can be found in the California Energy Commission (CEC) Residential Compliance Manual, published by the California Energy Commission.

2.6.1.2_Air Barriers

Air barriers are extremely important in controlling air infiltration between outdoors and conditioned interiors, providing both heating and cooling load control.

To ensure maximum air tightness of the construction, all fixed penetrations must be sealed properly and continuity must be provided at interfaces between systems and at all penetrations (e.g., windows and doors). The installation of the air barrier products requires oversight in order to ensure continuous adherence to the manufacturer's guidelines.

The Passive House Standard suggests a target for air tightness: a maximum of 0.6 air changes per hour at pressure of 50 Pascals (ACH50) or 0.2 inches of water, and verified with an onsite pressure test (in both pressurized and de-pressurized states).¹⁶ This Standard is considered best practice and may not be applicable to every project. However, it does shed light on what level of airtightness one might strive for to minimize heating and cooling loads related to air infiltration, and also to gain additional benefits from air-tight construction such as improved comfort and reduced energy consumption. For contrast, under the DOE Zero Energy Ready Homes program, leakage criteria varies from 1.5 to 3 air changes per hour, depending on Climate Zone.¹⁷

¹⁶ A 50 Pascal pressure is roughly equivalent to the pressure generated by a 20 mph wind blowing on the building from all directions. CFM50 is the most commonly used measure of building airtightness and gives a quick indication of the total air leakage in the building envelope. ACH50 (Air Change per Hour at 50 Pascals) is a way of normalizing leakage test results so that leakage in buildings of different sizes can be compared.

¹⁷ <https://basc.pnnl.gov/resource-guides/continuous-air-barrier-exterior-walls#edit-group-compliance>



2.6.2_USE ELECTRIC-DRIVEN HEAT PUMPS

One of the most important tools in the toolkit for all-electric building design is the heat pump. Like your refrigerator, heat pumps use electricity to move heat from a cool space to a warm space, making the cool space cooler and the warm space warmer (see Figure 2.12). During the heating season, heat pumps can move heat from the cool outdoors into your warm building, and, during the cooling season, heat pumps move heat from your cool building into the warm outdoors. Because they move heat rather than generate heat, heat pumps can provide equivalent space conditioning at as little as one quarter of the cost of operating conventional heating or cooling appliances.

Heat pumps are not some mystery technology — they have been around for decades. In fact, the concept was first proposed by Lord Kelvin in 1852 and the first working system was created in 1855 by Peter von Rittinger. It is reported widely that modern heat pumps were “invented” in 1948 by a man named Robert C. Webber, who burned his hand on a condenser coil while working on a deep-freeze freezer in his cellar beneath his home. Not wanting to be wasteful, Robert thought about how to use this heat from his freezer. Large scale heat pump applications more likely go back to the 1920s, when Aurel Boleslav Stodola, a Slovak engineer, physicist, and inventor working as a professor of mechanical engineering at the Swiss Polytechnical Institute in Zurich, constructed a closed loop heat pump (using source water from Lake Geneva) to heat the City Hall in Geneva.

It wasn't until the oil crisis of the 1970s that the heat pump became a more popular choice for heating and cooling homes. Thus, heat pumps have been in large-scale commercial production for over 50 years. Unfortunately, many systems installed in the early periods of this technology did not perform very well. This was not a problem with the technology but with the industry. Heat pumps are not as forgiving as gas furnaces (e.g. correct sizing is critical to optimal performance), and HVAC contractors did not fully understand the technology (many still don't).

FIGURE 2.12: BASIC HEAT PUMP REFRIGERANT CYCLE

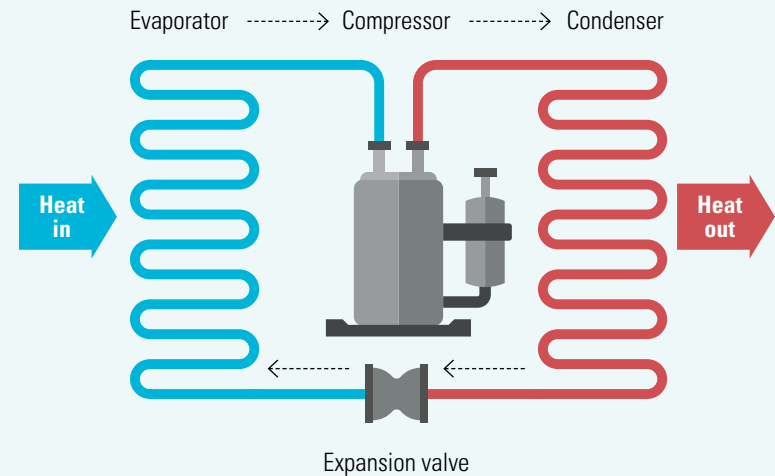

Source: On Air | <https://www.lghvacstory.com/heat-pumps-the-new-high-tech-energy-source/>

It is a myth that heat pumps only work in mild climates. This thinking stems from the fact that the performance of some heat pumps falls off as the ambient air temperature drops. Heat pumps have been used in extreme climates (like Alaska) for years. Today's air-source heat pumps easily perform down to 0 degrees F, and special low temperature units will work well to -15 degrees F and lower without electric resistance heat strips.

2.0_UNIVERSAL DESIGN, CONSTRUCTION, AND OPERATIONAL PHASE CONSIDERATIONS

Heat pumps are designed to pull thermal energy from a “source” and deliver thermal energy to a “sink.” Heat pumps come in multiple configurations for sources and sinks, which are generally either water or air. Heat pumps can be designed to move energy in one direction (i.e. always delivering heating energy or always delivering cooling energy to the sink); a chiller is, in essence, a heat pump that always takes heat out of the water being circulated through it and moves that heat to the outdoors via the air-cooled condenser or a cooling tower. With the inclusion of a reversing valve, heat pumps can change from delivering cooling energy to delivering heating energy. Heat pumps can also be designed to simultaneously deliver heating and cooling energy to separate sinks, and can use another dedicated component to act as a load balancing source or sink.

Thus, there are a number of configurations for heat pumps that allow for a wide application of equipment to the various heating and cooling needs of any facility.

Heat pumps are extremely effective at using electricity to move energy from a source to a sink. The efficiency (“coefficient of performance” or COP) of the system itself (the ratio between the electrical energy invested in order to run the heat pump and the heat pump’s energy output) varies between the types of system used. To calculate COP, the unit of energy consumed must be the same in the numerator and denominator.

- » **COP = Energy Output (kW) ÷ Energy Input (kW)**
- » **COP = Energy Output (BTUH) ÷ Energy Input (BTUH)**

Theoretical efficiencies of heat pumps vary based on source and sink temperatures (as shown in Figure 2.13). Electrical resistance heating, by comparison, can only have a theoretical COP of 1.0, and, in application, typically has an effective COP of less than 1.0.

FIGURE 2.13: HEAT PUMP COEFFICIENT OF PERFORMANCE (COP) VS. SOURCE TEMP

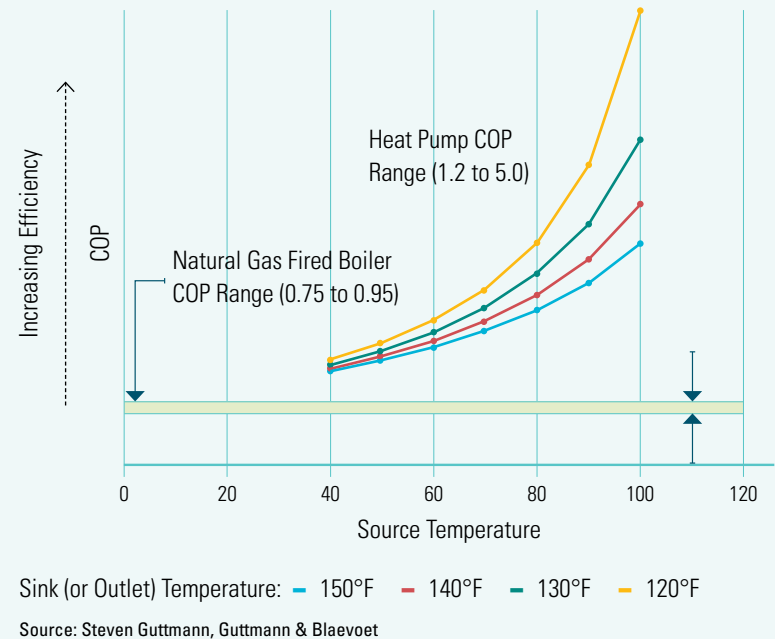

In real-world applications, heat pump system efficiency is dependent on many factors. Ground source heat pump systems tend to have a COP between 2.5 and 3. Air source heat pumps can be slightly less efficient, with an average COP of between 1.5 and 3. However, it must be noted that these values are increasing as technologies advance, and manufacturer’s claims of a products’ COP need to be carefully evaluated for source and sink assumptions.

Heat pumps are often paired with Dedicated Outdoor Air Systems (DOAS). A DOAS system removes the ventilation air load from the heat pump system, which can allow the heat pump to operate at higher efficiencies. DOAS systems often incorporate air-to-air heat exchangers for heat recovery from the exhaust air stream, further increasing the efficiency of the overall system.

2.6.2.1 Air-Source Heat Pumps

Some of the available air-source heat pump configurations include:

1. **Air-to-air heat pumps:** a heat pump that either heats or cools the air stream circulated to the building by drawing heat from or dumping heat to another airstream.
 - a. The most common air-source heat pump uses outdoor air to draw heat from or dump heat to. However, air-source heat pumps can also be successfully configured to use other air streams; for example, using the exhaust air from a building can be an extremely effective way of recovering energy that would otherwise be wasted.
 - b. The newer generation of air-to-air heat pumps allow for the integration of a domestic hot water heat recovery system to dump heat from the system refrigeration circuit into a domestic hot water system.
2. **Air-to-water heat pumps:** a heat pump that either heats or cools the water stream circulated to the building by drawing heat from or dumping heat to an airstream.
 - a. The most advanced air-to-water heat pumps have three water circulating loops: one for space heating hot water, one for space cooling water, and one for domestic hot water preheat. These heat pumps operate by moving energy from the chilled water loop and dumping that energy into the hot water loops, and vice versa. This “heat recovery” strategy allows these heat pumps to operate at

COPs as high as 7.5. The air coil is used when there is not enough sink for one of the sources (in this case, the coil is used to dump excess heating or cooling energy to the atmosphere), or for periods when all the available heat recovery is not enough to meet one of the loop’s demand (in this case, the coil is used to either draw heat from or reject heat to the atmosphere to supplement the recovered energy).

- b. Heat pumps that use CO₂ as a refrigerant are particularly well-suited to making hot water in cold climates. This is discussed in more detail in Volumes 3 and 4.

2.6.2.2 Water-Source Heat Pumps

Some of the available water-source heat pump configurations include:

1. **Water-to-air heat pumps:** a heat pump that either heats or cools the air stream circulated to the building by drawing heat from or dumping heat to a water source.
 - a. Common sources for water-source heat pumps include:
 - i. A water loop that is heated by an external heat source (historically, a natural-gas-fired boiler has been used, but all-electric designs would require another source), and cooled by a cooling tower, dry cooler, or other heat rejection device.
 - ii. A water loop that is connected to a network of pipes buried in the ground. This is generally referred to as a geothermal or ground-source heat pump (see Figure 2.15). A variation on this type of configuration adds a cooling tower to the ground loop, so that the size of the ground loop does not need to be adequate to serve peak loads; this is typically referred to as a hybrid ground-source heat pump.

2.0_UNIVERSAL DESIGN, CONSTRUCTION, AND OPERATIONAL PHASE CONSIDERATIONS

- b. Other sources for water-source heat pumps include:
- i. A water-loop that is connected to a body of water (river, lake, or ocean). This connection is typically accomplished via a heat exchanger. This heat exchanger can be a network of pipes submerged in the source. This can also be a conventional heat exchanger that has the heat pump's source water circulating in a loop on one side and water from the river/lake/ocean circulating on the other side. This is generally referred to as a geothermal or earth-coupled heat pump.
 - ii. A water loop that is connected to a coil in an airstream with a moderate, stable temperature, such as exhaust air from a building.
 - iii. A water loop that is connected to a heat exchanger that draws energy from water discharged into or flowing in a municipal sewer system. Typically referred to as Sanitary Wastewater Energy Exchange (or SWEE), this technology has been around for over 25 years, and there are more than 500 wastewater heat pumps in operation worldwide. One estimate is that Americans flush 350 billion kilowatt-hours of energy into the sewers each year — roughly enough to power 30 million U.S. homes.¹⁸
 - iv. A water loop that is connected to the discharge from an air-to-water heat pump. This configuration is typically used for applications of air-source heat pumps in cold climates that need to produce a hot water temperature over 90 to 100 degrees F. In this case, a water-source heat pump is used as a “second stage” (see Figure 2.14)

FIGURE 2.14: “CASCADED” OR TWO-STAGE AIR-SOURCE HEAT PUMP SYSTEM

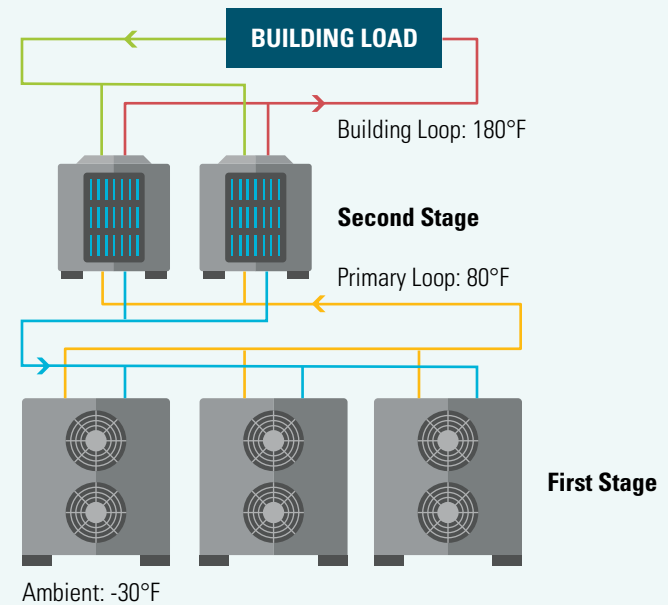

Source: Transom Corporation, Ontario, Canada

<https://www.transomcorporation.com/products/hatch-air-source-heat-pump/>

¹⁸ <https://www.nationalgeographic.com/science/article/121211-sewage-heat-recovery>

2.0_UNIVERSAL DESIGN, CONSTRUCTION, AND OPERATIONAL PHASE CONSIDERATIONS

- 2. Water-to-water heat pumps:** a heat pump that either heats or cools the water stream circulated to the building by drawing heat from or dumping heat to a water source.
- a.** Source water for this type of heat pump can come from the same sources as water-to-air heat pumps. Similar to air-to-water heat pumps, water-to-water heat pumps can have four water circulating loops: one for space heating hot water, one for space cooling water, one for domestic hot water preheat, and one for load balancing. These can be combined with any number of space conditioning strategies, including fan coil units, air handlers, and radiant heating and cooling systems.

FIGURE 2.15: WATER-TO-WATER GROUND SOURCE HEAT PUMP (GSHP)—SYSTEM SHOWN IN HEATING MODE

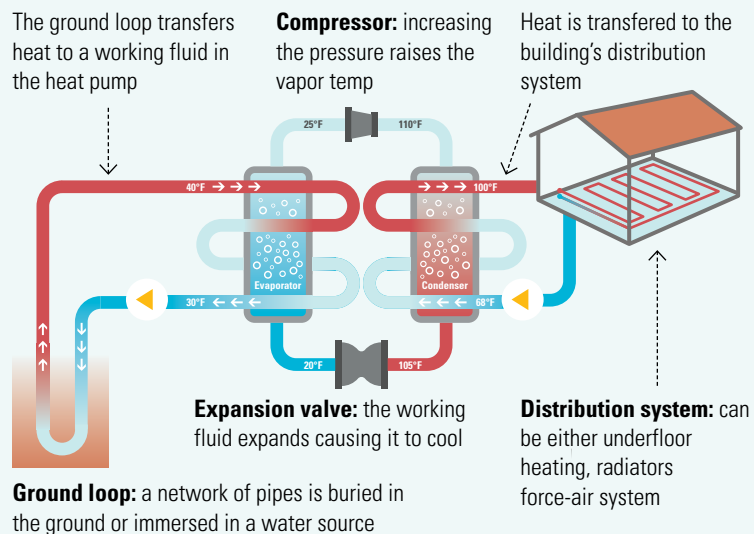

Source: <https://lakecountrygeothermal.com/geothermal-heat-pumps-and-ground-loops/>

2.6.2.3_Refrigerant-Based Heat Pump Systems

Variable refrigerant flow (or VRF) systems allow for energy to be exchanged between zones in heating and zones in cooling. VRF systems come in air-to-air and water-to-air heat pump configurations, and many can be equipped with an extra refrigerant-to-water heat exchanger that provides recovered energy for pre-heating domestic hot water.

2.6.2.4_Single-Pass Versus Multi-Pass System Configurations

Different configurations of central Heat Pump Water Heater (HPWH) systems are available. The primary configurations that are being used today are (see Figures 2.16 and 2.18):

- » Single pass
- » Multi-pass

FIGURE 2.16: SINGLE AND MULTI-PASS HEAT PUMP SYSTEMS

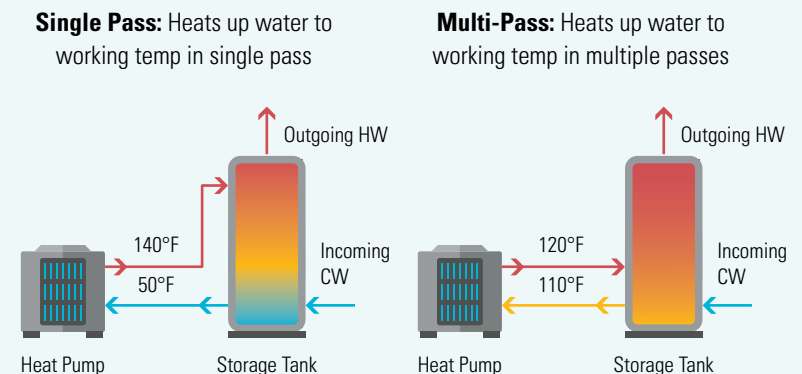

2.0_UNIVERSAL DESIGN, CONSTRUCTION, AND OPERATIONAL PHASE CONSIDERATIONS

2.6.2.4.1_MULTI-PASS SYSTEMS

Modeled on the design of conventional, natural-gas-fired, central water heating systems, “multi-pass” arrangements have been widely designed, installed, and operated.

Multi-pass systems are sensitive to:

1. The balancing of flows:
 - a. Each heat pump wants to see the same amount of flow. For systems that bring on each heat pump in a staged manner, this can require rigorous commissioning of the controls that regulate the amount of water flowing between the heat pumps and the storage tanks.
 - b. Water flow rates from the storage tanks to meet system demand should be balanced so that draw-off is relatively equally distributed.

- c. How recirculation water is tied into the storage system can affect the uniformity of tank temperatures. Recirculation water is colder than the storage temperature, especially in systems that store water at or above 140 deg. F and mix the temperature down to typical supply water temperatures (120 deg. F). Thus, poor configurations of return water connections can cause one or more tanks to drop in temperature quicker than the other tanks, with adverse impacts on heat pump system efficiency.
 - i. The use of “loop” or “swing” tanks, developed in response to the same optimization efforts that have resulted in the promotion of single pass design configurations, may be a way to mitigate these adverse effects in multi-pass systems as well.
2. Piping design that does not maximize thermal stratification in the storage tanks.

See an example of the impacts from a number of these issues in Figure 2.17.

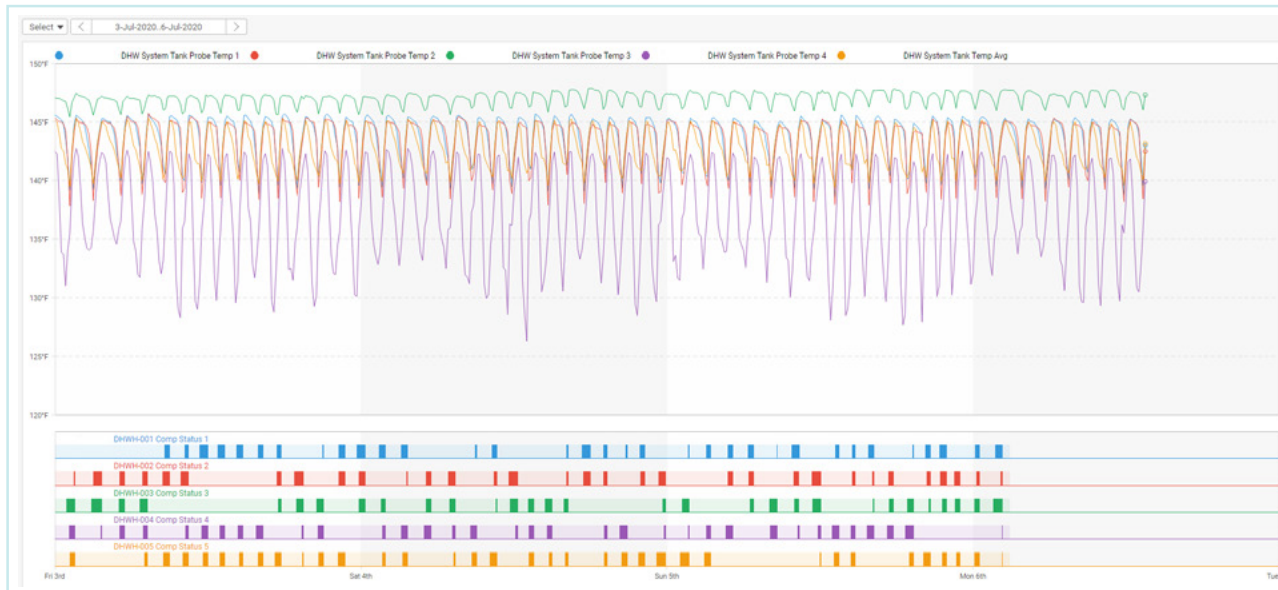
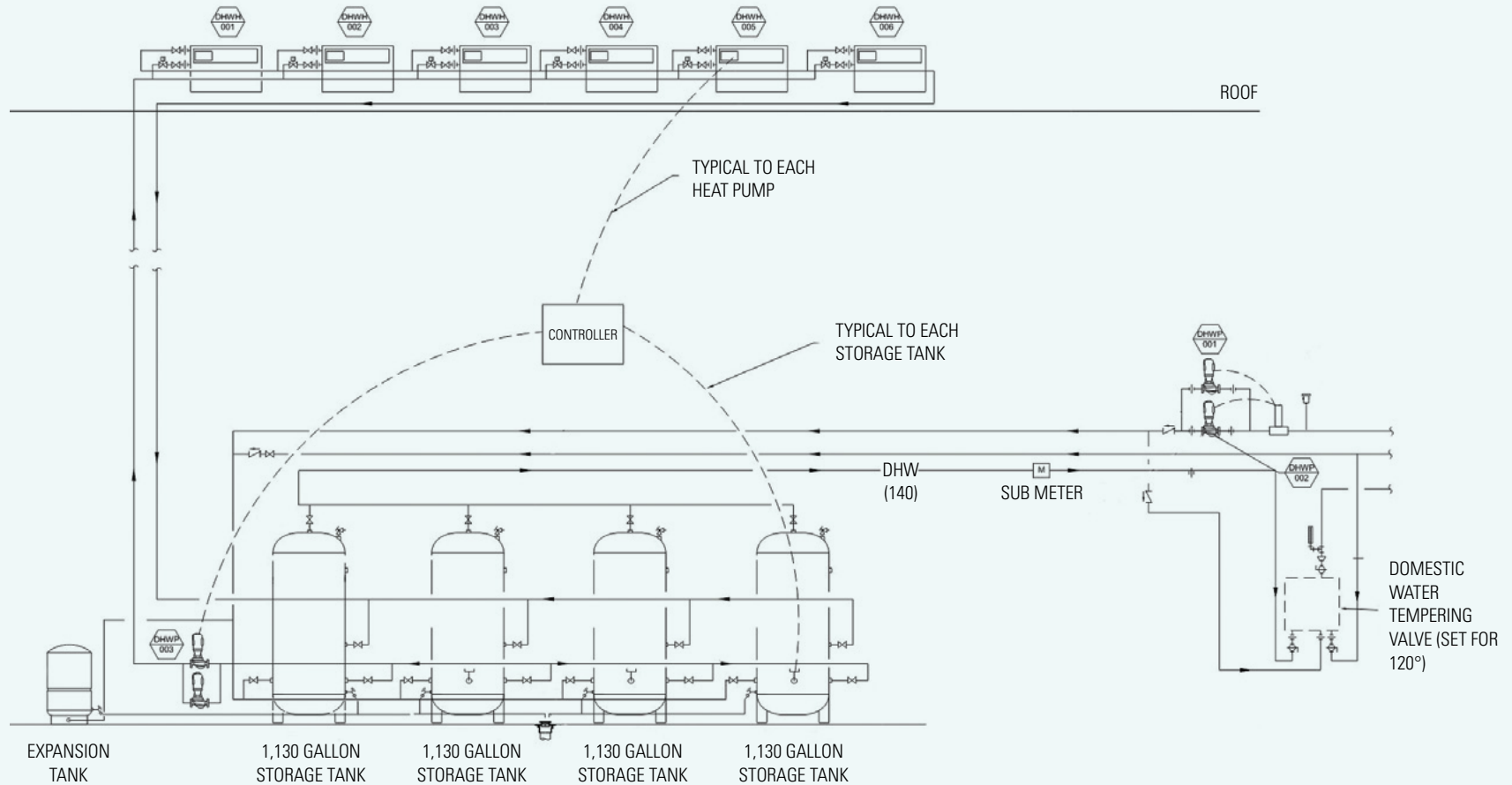

FIGURE 2.17: POORLY DESIGNED TANK CONFIGURATIONS CAN LEAD TO ADVERSE IMPACTS ON HEAT PUMP SYSTEM EFFICIENCY

Flow imbalances in this system are causing tank temperatures to vary significantly as well as causing excessive variations between storage tanks in the rate of charging and discharging.

2.0_UNIVERSAL DESIGN, CONSTRUCTION, AND OPERATIONAL PHASE CONSIDERATIONS

FIGURE 2.18: TYPICAL MULTI-PASS CENTRAL HPWH SYSTEM ARRANGEMENT WITH MULTIPLE AIR-SOURCE HEAT Pumps AND MULTIPLE STORAGE TANKS



2.0_UNIVERSAL DESIGN, CONSTRUCTION, AND OPERATIONAL PHASE CONSIDERATIONS

2.6.2.4.2_SINGLE PASS SYSTEMS

Studies on overall system efficiency suggest that “single pass” system arrangements may have advantages. Individual heat pump efficiency can be maximized by ensuring that the coldest water in the system (i.e. the make-up water) is what enters the heat pump(s).

FIGURE 2.19: PRESCRIPTIVE SIZING AND LAYOUT REQUIREMENTS FOR CENTRAL HEAT PUMP WATER HEATERS FOR MULTIFAMILY BUILDINGS

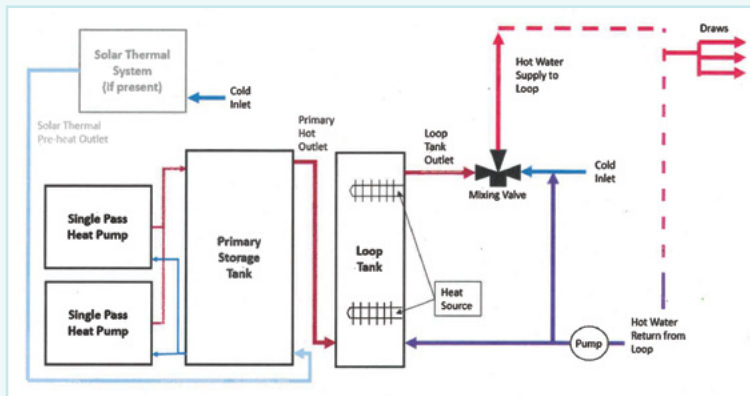

System schematic contained in the 2019 California Energy Commission’s Executive Director Determination, which serves as the basis for Code compliance in multi-family housing in California.

Source: California Energy Commission

While there is still debate regarding the superiority of single pass over multi-pass configurations, California has decided to codify the single-pass approach into the Energy Code for projects with “multiple dwelling units.”¹⁹ The “Executive Director Determination,” from the California Energy Commission issued on December 19, 2019 provides prescriptive requirements for the heat pump, storage tank, and “loop” or “swing” tank configurations (see Figure 2.19).

Multiple heat pumps and storage tanks can be used in single pass configurations. When multiple storage tanks are used, cold make-up water enters the heat pumps, and heated water leaves the heat pumps at the desired system delivery temperature (see Figure 2.20). The water leaving the heat pumps is connected to the last storage tank, which is arranged in a “cascade” arrangement so that the water stored gets colder and colder as the water flows from the last storage tank to the storage tank closest to the heat pump(s).

FIGURE 2.20: CONFIGURATION OF STORAGE TANKS IN A SINGLE PASS, MULTIPLE TANK ARRANGEMENT

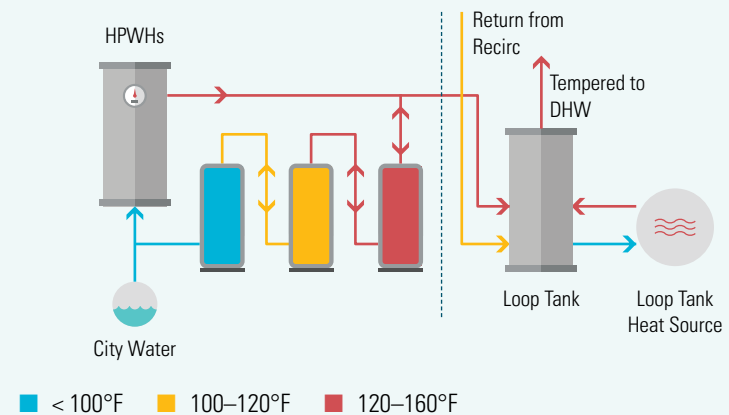

¹⁹ <https://efiling.energy.ca.gov/GetDocument.aspx?tn=231318>

2.6.2.4.3 _ TEMPERATURE MAINTENANCE CONSIDERATIONS

As discussed above, there are some key design considerations related to how recirculation loops are configured, how recirculation pumping systems are configured and controlled, and how the heat loss from the piping distribution system is replaced. Furthermore, while recirculation systems that consist of a pump and piping loops are commonly used in multifamily buildings to reduce wait time for hot water at faucets — saving large amounts of potable water — there is a large body of evidence that recirculation systems in central HPWH system design significantly impact overall system energy efficiency. According to a study performed by the US DOE’s National Renewable Energy Laboratory (NREL) in 2016, “distribution losses in multifamily buildings can account for 30%–50% of the energy input to the domestic hot water (DHW) system.”²⁰ Recirculation pumps and controls also consume energy. Finally, the efficiency of the heat pump itself may be degraded due to the arrangement of the recirculation loop and tank design.

To address some of these challenges there are a few solutions that can minimize energy use (see Figures 2.21 and 2.22). When combined with electrification of these systems, significant reductions in carbon emissions associated with these systems can be realized.

1. Controls for recirculation pumps:

- » The NREL study mentioned above evaluated three control strategies for recirculation pumps: “Demand” controls, “Temperature Modulation” controls, and the simultaneous operation of both. The results of the study — shown in the Table to the right — showed a significant energy savings potential from these alternate control strategies when used in combination.

FIGURE 2.21

Energy Use Reductions and Costs Saving by Technique		
Technique	Annual Energy Savings	Annual Cost Savings
Demand Control	7%	8%
TM	2%	1%
TM & Demand Control	15%	14%

Source: “Control Strategies to Reduce the Energy Consumption of Central Domestic Hot Water Systems,” Dentz et al, June, 2016.

2. Minimizing recirculation flows:

- » Methods for determining the flow rate and head requirements for recirculation pumps are fairly well established. However, large buildings can end up with a lot of horsepower dedicated to recirculation flows. In addition, without proper water balancing, proper recirculating system performance cannot be ensured. Means for minimizing the flow rate required to ensure that hot water is readily available throughout the system have been developed, such as thermostatic balancing valves. These devices can help avoid the added cost of water balancing for these systems.

²⁰ “Control Strategies to Reduce the Energy Consumption of Central Domestic Hot Water Systems,” Dentz et al, June, 2016.

FIGURE 2.22: TEMPERATURE MAINTENANCE SYSTEM ALTERNATIVES FOR SINGLE PASS SYSTEMS

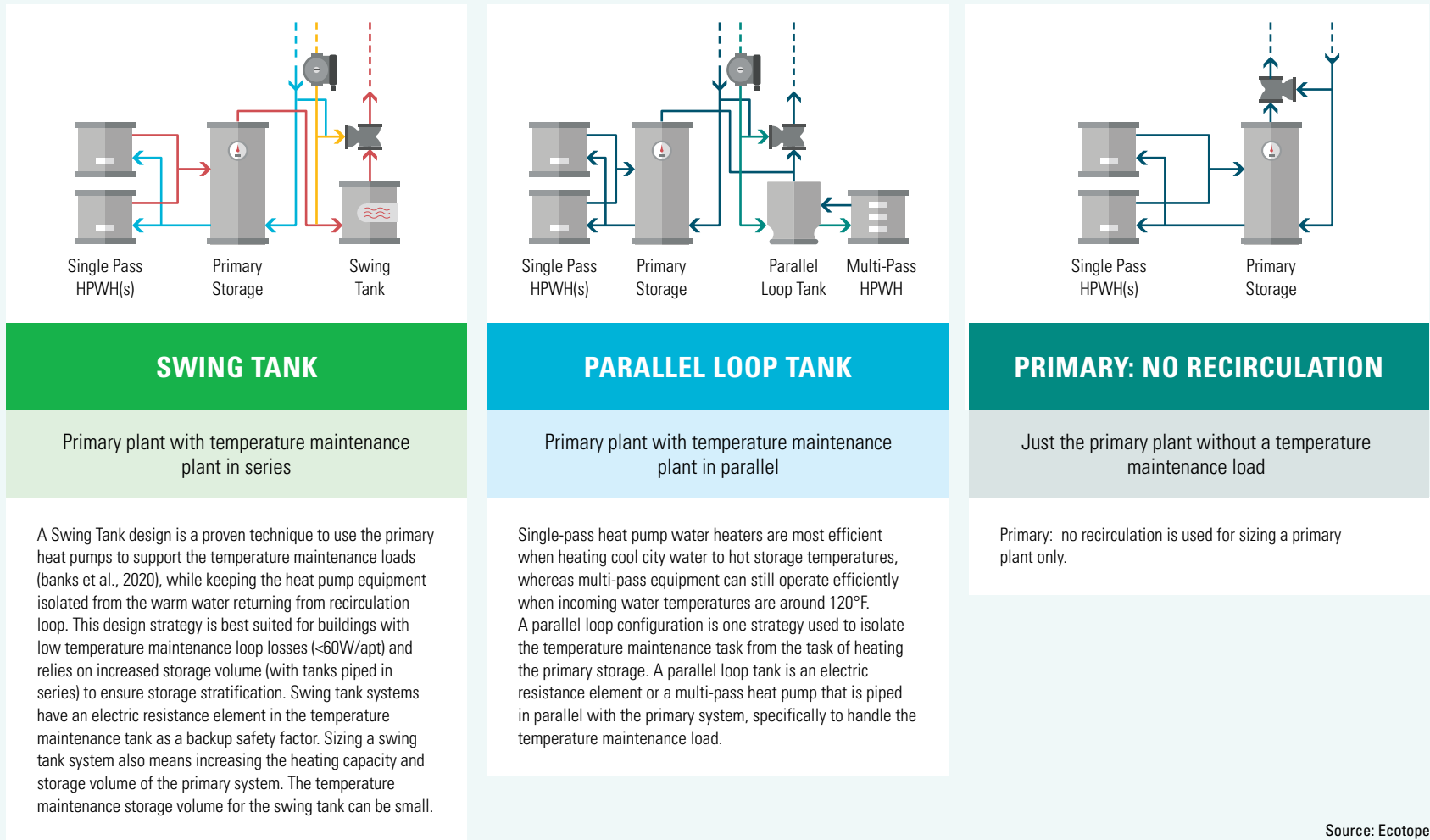

Source: Ecotope

3. Loop tanks:

- » As discussed above, there are design and operational challenges from the impacts of mixing cool return water back into multi-pass systems. Also, in single pass systems, the desire is to ensure that only the coldest water enters the heat pumps and only the hottest water leaves the storage system. Thus how to put heat back into the system that is lost in the distribution piping is a matter of some debate. The idea of the separate “loop” or “swing” tank that is provided with its own heat source is an approach that is gaining traction. Loop tank heat sources appear to be less critical from an overall efficiency standpoint: they can be a dedicated HPWH, a unitary tank-type HPWH, or even an electric resistance water heater (either standalone or tank-type).

4. Pipe insulation:

- » Energy Codes generally specify the minimum insulation required for all piping in a DHW system. Since water is essentially stagnant in DHW circulating systems for long periods of time, minimizing the rate of heat loss to the ambient air can be effective at reducing overall heat losses. So, using an insulation thickness one size larger than required by Code can be a cost effective measure to reduce energy use in DHW systems.

2.6.3_ELIMINATE REHEAT

Reheat is the energy transfer process where heat is added to air that has already been cooled. Central HVAC systems typically employ reheat so that one system can be used to serve a number of zones with different loads and load profiles. Such zones need different amounts and/or temperatures of air at any given hour of the day to meet their load. The energy crisis of the late 1970s made central variable air volume (VAV) systems with reheat one of the most common types of HVAC systems employed in commercial buildings over the past forty years. While this type of system was developed

in order to reduce the energy used by its predecessor —constant volume systems with reheat — a significant amount of energy in VAV systems is still used to reduce the amount of cooling by reheating air.

By its nature, reheat is a waste of energy, since energy has been previously invested to cool down the air stream. Elimination of reheat can be accomplished by a variety of design strategies. Available configurations either “decouple” the energy used to meet zone heating and cooling loads from the energy used to condition ventilation air or bring in ventilation air at the zone level. Decoupled zonal heating and cooling systems typically rely on “dedicated outdoor air systems” for meeting ventilation requirements. Air from a DOAS system is usually delivered to each space at a “neutral” temperature (i.e. somewhere between 68 and 72 degrees F) in order to allow the zone heating and cooling system to respond to zone loads only. Examples of these systems include:

1. Decoupled systems

- » Two-pipe or four-pipe fan coil units
- » Unitary air-source or water-source heat pumps (ASHPs or WSHPs)
- » Variable Refrigerant Flow (VRF) systems (also known as Variable Refrigerant Volume, or VRV systems)
- » Passive or active chilled beams
- » Radiant heating and cooling

2. Systems that can bring in ventilation air at the zone level

- » Two-pipe or four-pipe fan coil units
- » Unitary ASHPs or WSHPs
- » VRF systems

2.6.4_SUB-METERING

Zero Net Energy (ZNE) is an energy accounting strategy for zeroing out emissions caused by demand for grid electricity. The most effective ZNE buildings are those that reduce annual energy consumption through passive design and other energy efficiency techniques, and then match or slightly exceed that annual consumption with annual output from on-site renewable energy sources (most commonly photovoltaic or PV systems). In the most basic systems, utility companies that allow for net energy metering²¹ (NEM) will report the net monthly grid energy used or net site energy delivered to the grid, allowing an owner to track annual energy usage in order to ensure that the net amount of grid energy consumed is zero. Such a system will monitor energy demand and energy output, and that data can be compared to the results of a predictive energy model created during the design phase. See Figure 2.23 for an example of what those comparisons look like.

FIGURE 2.23: ALPINE BRANCH LIBRARY YEAR ONE ZNE

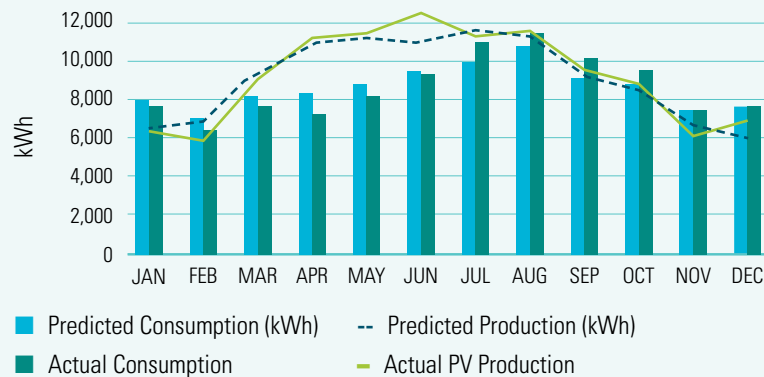

Source: Courtesy of Energy & Sustainability Program, County of San Diego

²¹ Net energy metering is a mechanism that allows domestic or commercial users who generate their own electricity using solar panels or photovoltaic systems to export their surplus energy back to the grid.

Achieving this annual balance, however, cannot be confirmed until the end of each year. Thus, methods that help to ensure that this balance is achieved are extremely useful. The graph on this page reflects a “well-behaved” building, but operational or design issues can result in actual monthly consumption and production values that vary significantly from predicted values. Even well-behaved buildings can go through a start-up period that can last for months in order to get the building to operate as intended. The installation of electricity sub meters that measure end uses (e.g. lighting, HVAC, plug and process loads, elevators, etc.) can provide more granular energy use data that can be compared against a predictive energy model: this can both facilitate the identification of specific energy usage that significantly deviates from predicted values and assist in quickly establishing corrective measures to bring actual energy use into conformance with predictions. Thus, the use of submetering systems can significantly reduce the effort and time needed to respond to issues that may undermine the attainment of a ZNE goal.

Submetering can have benefits beyond managing ZNE goal achievement. A report by the National Science and Technology Council on submetering of building power usage found that: “Numerous case studies provide evidence that the ROI [on installing submeters] can be significant...Further, submetering provides the necessary infrastructure for more advanced conservation and efficiency techniques.”²² In this report and others, submetering is hailed as the new gold standard because of its potential for increasing the sustainability of building operations by reducing waste and cost, changing user behavior in positive ways, and improving operations efficiency. A General Services Administration study on the business case for submetering discusses the financial implications of using submetering as a means of energy cost management and reduction in federal facilities or commercial leased buildings;²³ it introduces the concept of submetering and its “value added” applications, and it provides key metrics needed for making a business case for submetering efforts as part of new construction or retrofit projects.

²² “Submetering of Building Energy and Water Usage: Analysis and Recommendations of the Subcommittee on Buildings Technology Research and Development”, National Science and Technology Council Committee on Technology, Subcommittee on Buildings Technology Research and Development, October 2011.

²³ “Submetering Business Case: How to calculate cost-effective solutions in the building context” <https://www.gsa.gov/governmentwide-initiatives/federal-highperformance-green-buildings/resource-library/energy-water/submetering>.

2.6.5_GRID RESPONSIVE DESIGN

Electrification is a strategy to eliminate greenhouse gas emissions from the load side of the meter. However, regardless of the percentage of renewables in the fuel mix of your local grid, when the sun is not shining and the wind is not blowing grid managers rely for the most part on fossil fuels to meet demand. This is why the time of day that energy gets used matters. Figure 2.24 shows the demand profile at a typical ZNE building. Facilities that stay open into the evening and nighttime hours experience a similar profile; demand during hours of energy use that is met by grid-supplied energy will have higher carbon content than hours when renewable energy sources are at peak production.

FIGURE 2.24: ALPINE LIBRARY ENERGY PROFILE

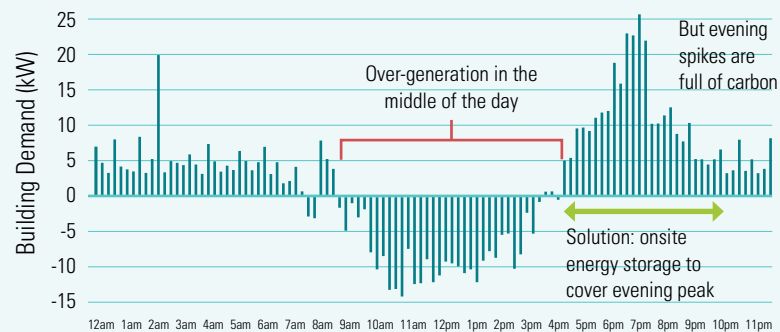

Source: Courtesy of Energy & Sustainability Program, County of San Diego

On the grid side, a typical emissions profile for a day may look like Figure 2.25,²⁴ which shows the Marginal Emissions Rate (MER) of grid-supplied energy over the California Independent System Operator's (CAISO) daily load profile above a building demand profile.

²⁴ From a Grid Optimal Pilot Project report prepared by the New Buildings Institute, October, 2018.

Energy suppliers on different regional grids experience different power generation management issues based on the different types and amounts of renewable energy connected to their grid (see Figure 2.26). Thus, building system design strategies for grid harmonization will be different in each grid "climate." Harmonization design strategies will allow for the timing of loads to be targeted to periods with a low marginal emissions rate, whenever they occur on any particular grid.

FIGURE 2.25: MARGINAL EMISSIONS RATES AND BUILDING ENERGY DEMAND

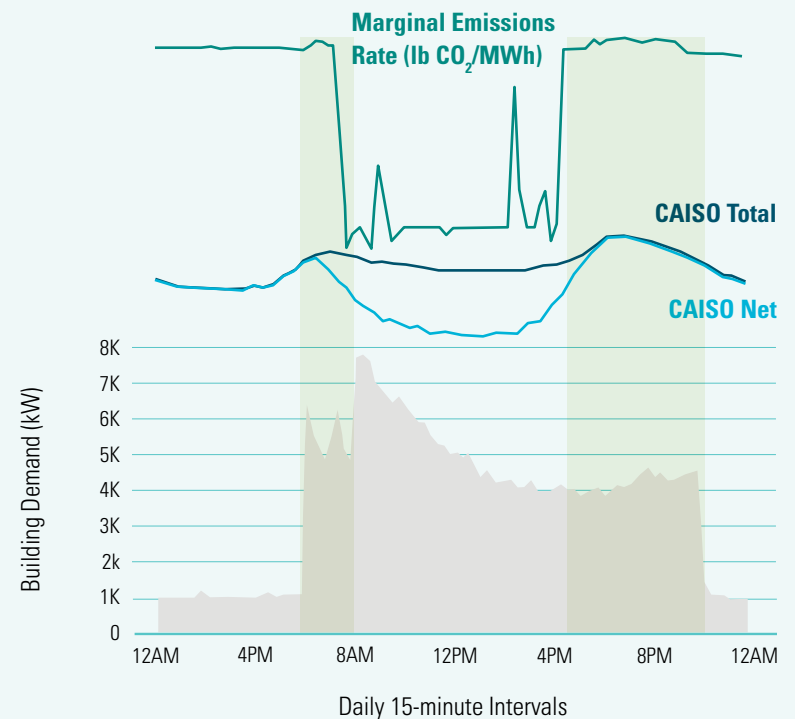

Source: New Buildings Institute

FIGURE 2.26: EFFECTS OF DIFFERENT RENEWABLES MIXES ON REGIONAL GRID LOAD PROFILES

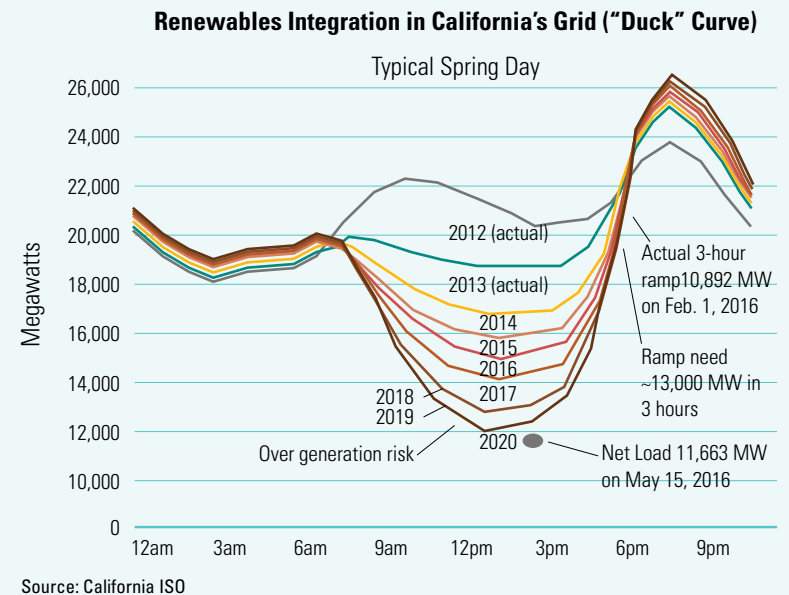
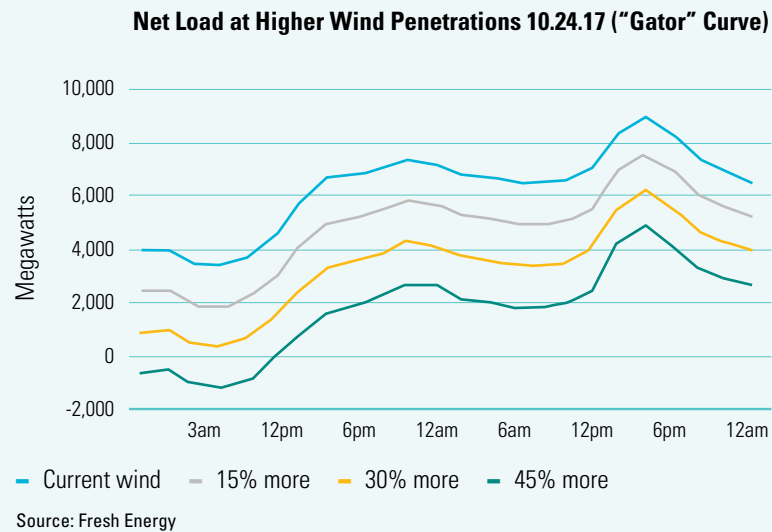

CAISO experiences a “Duck Curve” in power plant demand based on a large amount of solar energy on the grid, while the Midcontinent Independent System Operator (MISO) experiences a “Gator Curve” due to a large amount of wind energy supplied to the grid.

Building system solutions that can facilitate the timing of loads include load shifting strategies (such as thermal storage), energy storage systems that charge and discharge based on grid MERs, demand limiting strategies (such as dimming lights and resetting building temperature setpoints), and load deployment strategies (such as limiting domestic hot water heat pump operation or car charging to hours when MERs are low). Figure 2.27 shows the differences in the load profiles of a conventional energy efficient building, one with a PV system added, and a truly “grid-integrated” building.

The New Building Institute’s GridOptimal Initiative²⁵ has developed new metrics by which building features and operating characteristics that support more effective grid operation can be measured and quantified.

So, while conventional, energy efficient, and even ZNE designs fall short when it comes to decarbonization, a grid integrated or “grid harmonized” building design can address both energy efficiency and carbon emissions reductions.

²⁵ <https://newbuildings.org/resource/gridoptimal/>

FIGURE 2.27: GRID INTEGRATED BUILDING: LOAD PROFILES

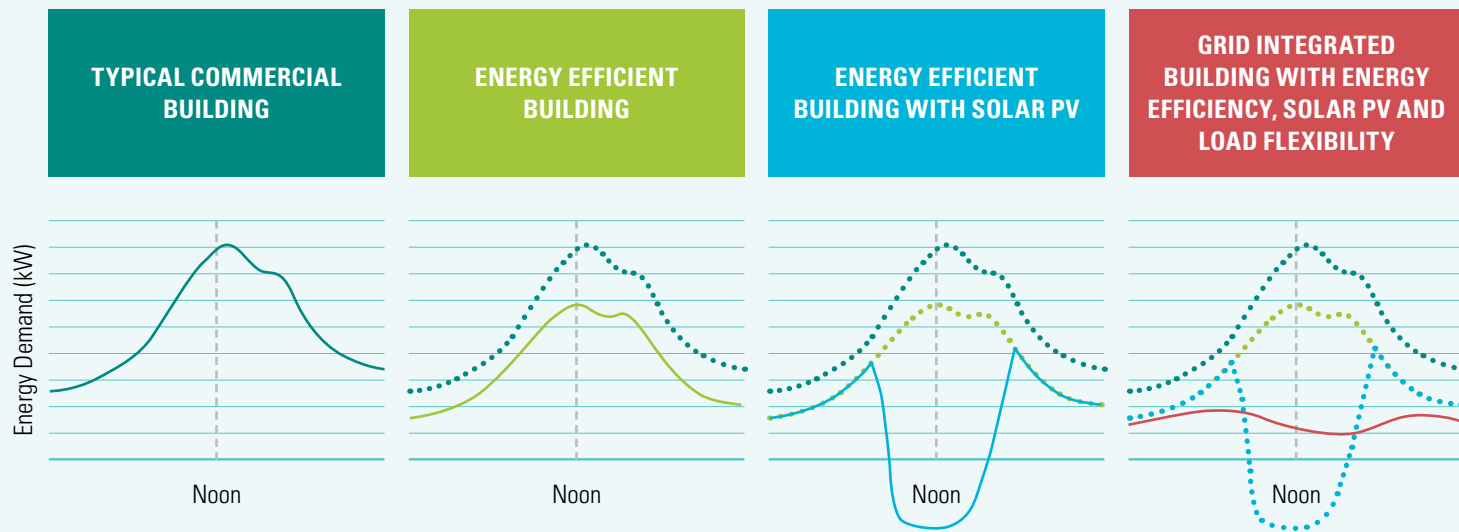

Source: Cara Carmichael, RMI

Efficiency improves curve (lowers and flattens)

- + Reduces energy consumption and demand changes

Adding solar offsets significant loads, often coincident with utility peak loads

- + Reduces energy consumption and demand changes
- + Can cause steep ramping of loads and utility issues

Grid integration combined with the other strategies shifts building loads to match generation, further reducing peaks

- + Optimizes energy consumption and demand charge savings while supporting grid stability and resilience
- + Demand response capability during grid peak scenarios provides additional revenue

2.6.5.1 Energy Storage

The increasing availability of renewable energy on electrical grids creates challenges for grid managers. The problem with most renewables is that their generation is variable in nature. One solution to solve that variability is to use energy storage, effectively decoupling the need to match the timing of energy generation and use.

Utility scale energy storage systems are expensive and complicated to deploy in order to maintain grid stability. Nevertheless, “driven by steeply falling prices and technological progress that allows batteries to store ever-larger amounts of energy, grid-scale systems are seeing record growth in the U.S. and around the world. California is currently the global leader in the effort to balance the intermittency of renewable energy in electric grids with high-capacity batteries. But the rest of the world is rapidly following suit. Recently announced plans range from a 409-megawatt system in South Florida, to a 320-megawatt plant near London, England, to a 200-megawatt facility in Lithuania and a 112-megawatt unit in Chile.”²⁶

Onsite energy storage systems, by comparison, are relatively easy to install and manage. Building-scale battery energy storage systems (BESS) are becoming more readily available and adaptable. While still relatively expensive, they can be used to reduce utility costs (consumption and demand charges) as well as reduce a building’s carbon footprint. Distributed energy storage in buildings is expected to play an increasing role in the future energy transition, and BESS are not the only type of energy storage system that can be applied at the building scale. Other options, some commercially available and some that are still in the early stages of commercialization, include:

²⁶ <https://e360.yale.edu/features/in-boost-for-renewables-grid-scale-battery-storage-is-on-the-rise>

²⁷ <https://spectrum.ieee.org/energy/policy/a-pumped-hydro-energy-storage-renaissance>

SYSTEM THAT CAN STORE “POTENTIAL ENERGY”

1. Flywheels

- » These are being used at both the utility and building scale. Flywheel energy storage (FES) works by accelerating a rotor (flywheel) to a very high speed and maintaining the energy in the system as rotational energy. When energy is extracted from the system, the flywheel’s rotational speed is reduced as a consequence of the principle of conservation of energy; adding energy to the system correspondingly results in an increase in the speed of the flywheel. Beacon Power opened a 5 MWh (20 MW over 15 mins) flywheel energy storage plant in Stephentown, New York in 2011, and a similar 20 MW system at Hazle Township, Pennsylvania in 2014. A 2 MW (for 15 min) flywheel storage facility in Minto, Ontario, Canada also opened in 2014. Amber Kinetics, Inc. has an agreement with Pacific Gas and Electric (PG&E) for a 20 MW / 80 MWh flywheel energy storage facility located in Fresno, CA with a four-hour discharge duration.

2. Elevated water storage

- » A 2015 article from IEEE Spectrum notes that “pumping water uphill to store energy in hydropower reservoirs is an idea that, by power grid standards, is as old as the hills that such ‘pumped storage’ plants are built on. But with the rise of intermittent solar energy and wind power, this technology could soon experience a revival, experts say.”²⁷ In 2015, Citibank estimated that the cost of power from pumped hydroelectric was about 5 percent of the cost of grid-scale battery-stored electricity. Pumped storage hydro is by far the most successful energy storage technology, representing most of the installed storage capacity worldwide, although for large installations. This prompts the question of whether such technology could be used on a much smaller, building scale (see Figure 2.28). Design of cost-effective, small-scale pumped storage hydroelectric systems can be a challenge.

FIGURE 2.28: RETROFITTING WATER TOWERS FOR HYDROELECTRIC POWER

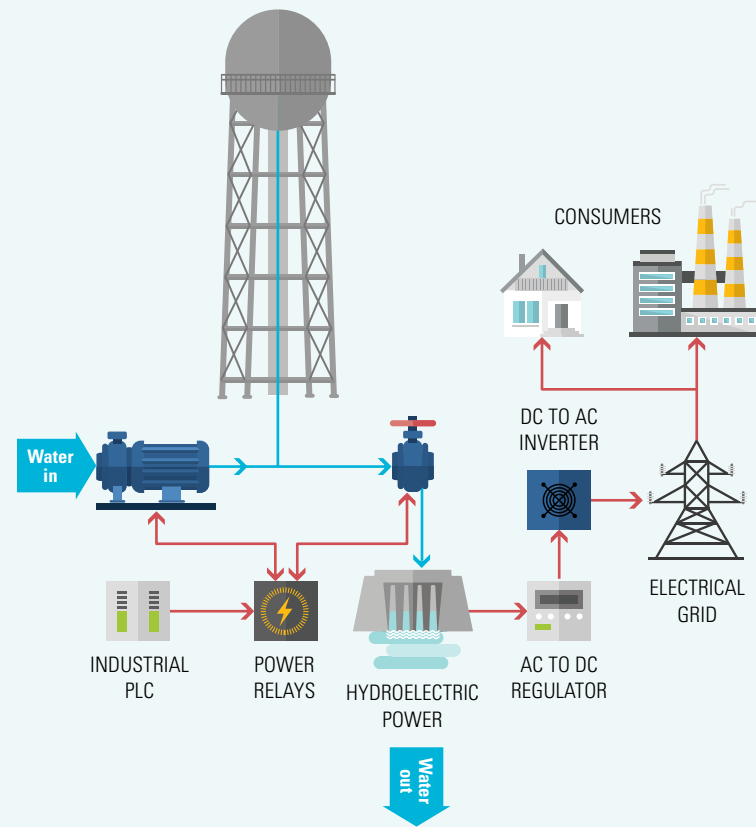

Source: From "Retrofitting Water Towers for Hydroelectric Power Generation," Viorel Miron-Alexe, Valahia University of Targoviste, Institute of Multidisciplinary Research for Science and Technology, Targoviste, Romania. Published online: 30.12.2019.

3. Creating green hydrogen from excess solar energy

» There is a growing international consensus that clean hydrogen will play a key role in the world's transition to a sustainable energy future (see Figures 2.29 and 2.30). While the cost-effectiveness of using electricity to create hydrogen (via electrolysis of water) is debatable, the ability to create and store hydrogen gas using solar energy that might otherwise be "wasted" allows hydrogen to act as an energy storage medium. Such stored gas could be used to power fuel cells or even direct combustion. The world's first hydrogen-powered domestic boiler was put into operation in Rozenburg, the Netherlands in 2019 (<https://www.bdrthermeagroup.com/en/products-and-services/products/hydrogen-boilers>). Mixing hydrogen with methane for delivery through existing utility infrastructure, as well as other ways to create a more "green" alternative for methane, are increasingly seen as strategies that cannot be developed fast enough and at an adequate scale to be serious contributions to decarbonization goals.

FIGURE 2.29: HYDROGEN CAN PLAY MANY ROLES IN A DECARBONIZED ENERGY SUPPLY TRANSITION

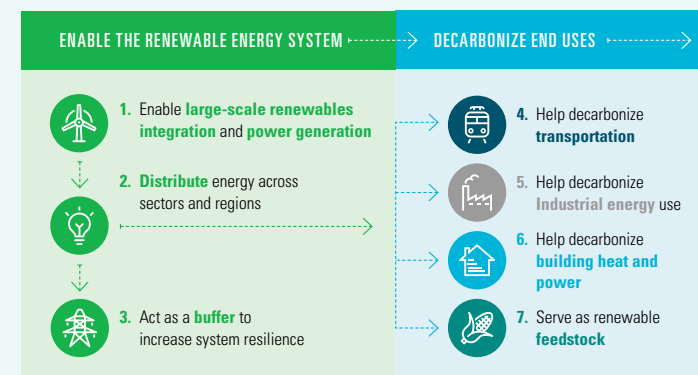

Source: Hydrogen Council

<https://hydrogencouncil.com/wp-content/uploads/2017/11/Hydrogen-scaling-up-Hydrogen-Council.pdf>

FIGURE 2.30: POTENTIAL DEMAND FOR HYDROGEN

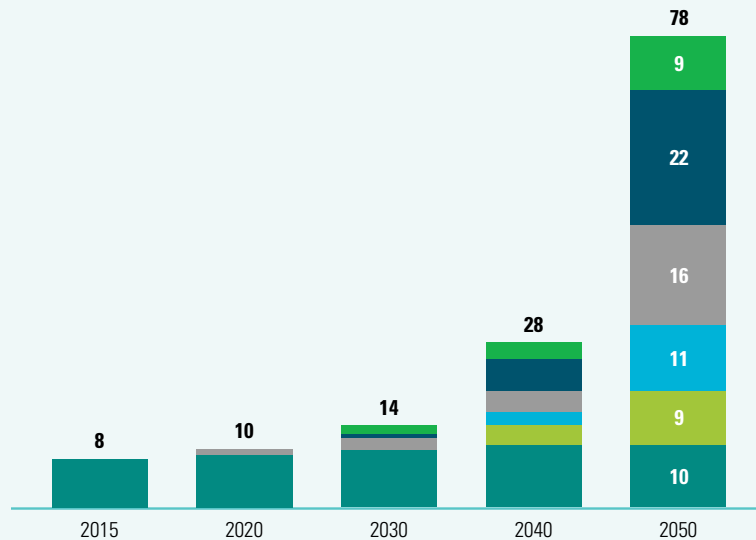

Power generation buffering



Building heat and power



Transportation



New feedstock (CCU, DRI)



Industrial energy



Existing feedstock

Source: CleanTech | <https://www.enapter.com/media-coverage/cleantech-com-the-role-of-green-hydrogen-in-global-decarbonization>

2.6.5.2_Demand Response and Deployable Loads

Managing building energy use in a manner that is responsive to grid capacity and stability is known as “Grid Harmonization.” Strategies that accomplish this can also be used to take maximum advantage of renewable energy when it is available on the grid.

Demand response programs can serve as a major tool for accelerating the use of renewable energy and balancing electricity load on a grid (see Figure 2.31). When there is excess energy on the grid (for grids that incorporate solar PV capacity, this is primarily during the middle of the day when solar generation peaks), utility companies can encourage participating smart devices to charge, pre-cool, or pre-heat themselves. When there is demand for electricity and available sources are being fully utilized, utility companies can slow or delay participating smart devices until the grid is cleaner, preventing the need for electricity generated by the dirtiest fossil fuels. These smart devices represent loads that can be deployed by grid operators when they want to increase usage to take advantage of available excess renewable energy as well as when decreasing usage is necessary for grid load management.

The Energy Independence and Security Act of 2007 (EISA) gave the National Institute of Standards and Technology (NIST) the primary responsibility to coordinate development of a framework that includes protocols and model standards to achieve interoperability of smart devices and systems that interact with the electricity grid. Many utility companies are developing programs for controlling electric vehicle charging stations, domestic hot water heat pump water heaters, and smart thermostats located in residences, and equipment manufacturers are incorporating software to make these devices interoperable with demand response signals from utilities. Building automation systems can also be used to control the deployment of these loads, allowing owners to maintain control over their assets.

Changes are happening rapidly, and everyone should be watching for this decarbonization strategy to become business as usual in order to facilitate the transition of regional grid supplies to 100% renewable energy.

FIGURE 2.31: TYPES OF DEPLOYABLE LOADS THAT CAN BE INTEGRATED INTO A UTILITY DEMAND RESPONSE PROGRAM

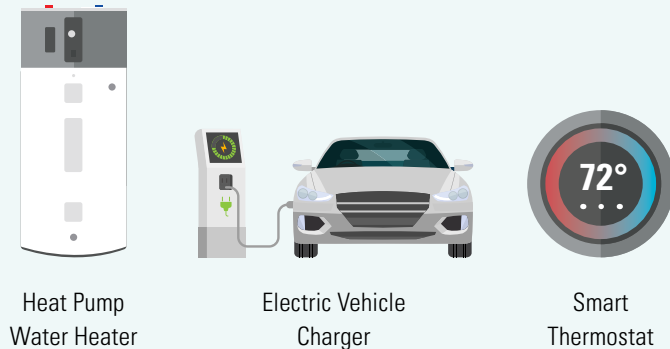

Source: Sonoma Clean Power's "Grid Savvy" Demand Response Program Brochure

2.6.5.3 Load Shifting and Thermal Storage

Traditionally, load shifting has been implemented to save money by reducing peak electricity demand (hence, reducing demand charges) and by shifting energy use to hours when less expensive, non-peak rates apply; this creates thermal energy that can be stored and used at a later time to avoid electricity use during peak rate hours. Under a decarbonization paradigm, load shifting will use energy when electricity is available with low or no marginal emissions to create thermal energy that can be stored and used during periods when marginal emissions rates are high.

Some of the technologies that enable systems to shift the time that peak loads occur can also facilitate the timing of grid-purchased energy (see Figure 2.32) in order to utilize electricity with the lowest marginal emissions rate (i.e. loads that can be "deployed" for maximum grid harmonization).

With respect to all-electric buildings, 24/7 facilities have unique and expanded opportunities for load shifting and thermal storage, allowing for significant reductions in the capacity of heating and cooling plants.

Technologies available to accomplish load shifting and demand reduction include:

1. **Thermal storage (ice or water):** this is one of the most effective load shifting technologies available that also contributes to grid harmonization because it produces chilled water (or ice) and hot water at times when the source of electricity has low or no marginal emissions.

FIGURE 2.32: TYPICAL THERMAL STORAGE SYSTEM

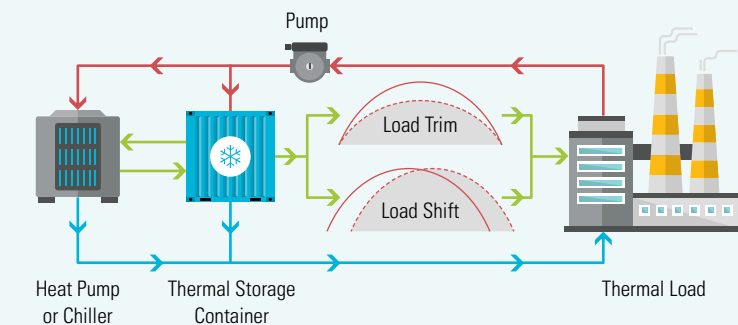

Source: BioPCM

2. Super-insulated envelopes (e.g. Passive House design):

- » Super-insulated envelopes delay the transfer of energy from the outdoors to the indoors. This has the benefit of reducing peak loads as well as shifting the time of day that systems see the maximum impact from exterior loads to a later hour of the day.

3. Phase change materials embedded in the construction:

- » Phase change materials (PCMs) are substances that store and release thermal energy as they transition from one phase to another (e.g. solid to liquid). During a phase change, molecules rearrange themselves and cause an entropy change that results in the absorption or release of latent heat, meaning the temperature of the material itself remains constant as a great deal of energy is absorbed before melting and released before freezing (see Figure 2.33). For example, when heat is applied to a block of ice, the ice and resulting melted water remain at or near 32°F until the phase change is complete (i.e. there is no more ice). The heat is absorbed as latent heat until the ice completely changes phase into water. Conversely, when heat is removed from a pool of water, the temperature of the water and resulting ice will not fall below 32°F until the water completely changes phase into ice. When a PCM is installed, it absorbs heat (melts) when ambient temperature exceeds target room temperature, and it releases heat (freezes) when ambient temperature falls below target room temperature. Through this recurring process, ambient temperature within the managed environment is stabilized around the target room temperature. As a result, less mechanical cooling is required, and HVAC power consumption is greatly reduced.
- » While this technology can be “tuned” to a project’s specific needs (i.e. the temperature at which the phase change occurs can be adjusted based on the properties of the PCMs used), deployment cannot necessarily be timed to coincide with low marginal emissions rates.

FIGURE 2.33: LATENT HEAT (ABSORPTION AND RELEASE)

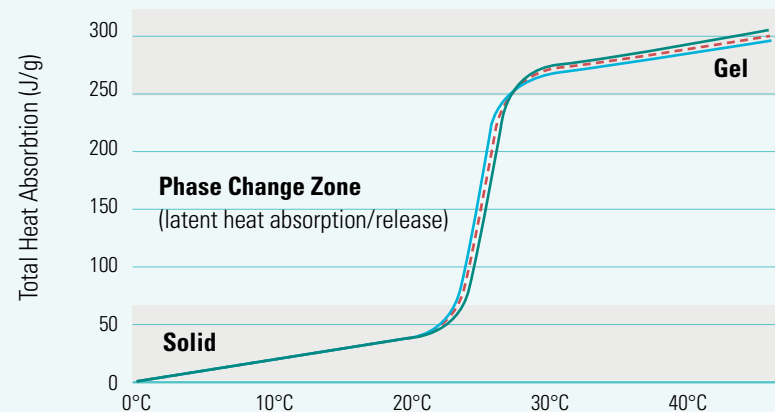

Number of cycles: — 0 — 12,000 — 36,500

Enthalpy of BioPCM® (Q25) demonstrates excellent energy storage performance through thousands of phase change cycles.

Source: BioPCM | <https://phasechange.com/enrgblanket/>

4. Thermal mass

- » Thermal mass is a property of the materials in a building to store energy (heat), providing "inertia" against temperature fluctuations. Thermal mass will absorb thermal energy when the surroundings are at a higher temperature than the mass itself, and give thermal energy back when the surroundings are cooler. The use of materials with high thermal mass is most advantageous where there is a big difference in outdoor temperatures from day to night; flushing a building with outside air at night can cool down the mass, which allows the mass to absorb significant amounts of heat during the day.
- » Thermal mass has similar characteristics with respect to grid harmonization that PCMs do, but without the PCMs' ability to "tune" the energy transfer.
- » Materials commonly used for thermal mass include:
 - Concrete, clay bricks and other forms of masonry: the thermal conductivity of concrete depends on its composition and curing technique. Concretes with stones are more thermally conductive than concretes with ash, perlite, fibers, and other insulating aggregates.
 - Clay brick.
 - Adobe brick or mudbrick.
 - Earth, mud and sod: dirt's heat capacity depends on its density, moisture content, particle shape, temperature, and composition.
 - Rammed earth: rammed earth provides excellent thermal mass because of its high density and the high specific heat capacity of the soil used in its construction.
 - Natural rock and stone.
 - Water: water has the highest volumetric heat capacity of all commonly used materials. Typically, it is placed in large containers (for example, acrylic tubes as shown in Figure 2.34), in an area with direct sunlight.

FIGURE 2.34



Source: Trombe wall | <https://www.thenaturalhome.com/heatstorage/>

2.0_UNIVERSAL DESIGN, CONSTRUCTION, AND OPERATIONAL PHASE CONSIDERATIONS

2.6.6_MAXIMIZING ON-SITE RENEWABLE ENERGY GENERATION

The biggest immediate concerns with electrification tend to be centered around the potential to stress local grid capacity and potential short term increases in operational-energy related carbon emissions due to the local utility feeding “dirty” energy onto the grid. As discussed in Volume 7,

“Policy and Code Context,” many U.S. states still use large amounts of coal for generating electricity (see Figure 2.35). In Iowa for example, coal produced 35% of the state’s electricity in 2019 (down from 85% in 2001). Data for 2019 suggests that, nationally, 23% of total electricity generation was still done with coal (a reduction of over 50% since 2008),²⁸ and the EIA estimates that coal use was further reduced to producing only 19% of total electricity generation in 2020.²⁹

FIGURE 2.35: PRIMARY POWER SOURCE BY STATE

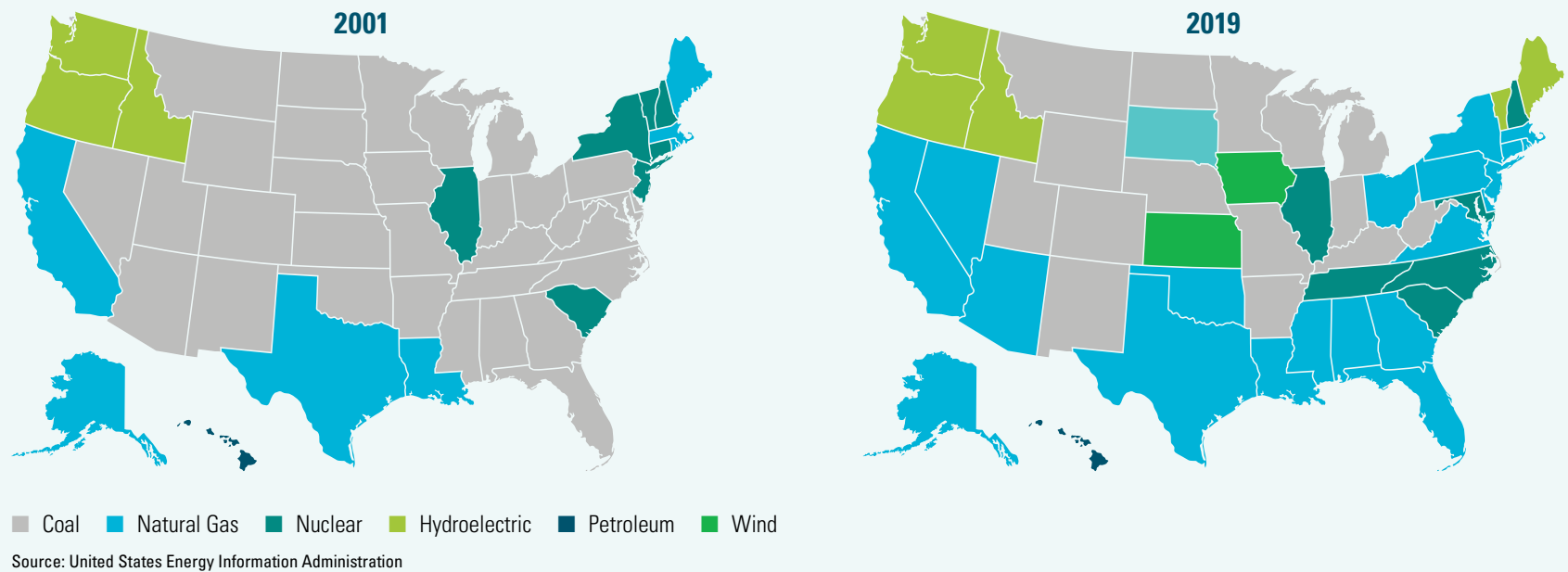

²⁸ [How Does Your State Make Electricity?](#)

²⁹ [Electricity in the US - US Energy Information Administration](#)

2.0_ UNIVERSAL DESIGN, CONSTRUCTION, AND OPERATIONAL PHASE CONSIDERATIONS

Rather than take the position that all-electric buildings are a bad choice for reducing operational GHG emissions, Section 2.4.1 suggests that projects develop strategies to offset emissions from utility-purchased energy that occur between completion and decommissioning. Options include, where available, purchasing electricity from a provider that can supply 100% renewable energy to incorporating onsite or offsite renewable energy generation to offset emissions.

With paybacks on investments in PV systems currently ranging from a low of 5 years (e.g. in Hawaii and Massachusetts) to as long as 16 years (e.g. in Louisiana and North Dakota), these investments will always pay themselves back over the life of a building, even without factoring in the utility price risks if a cost of carbon emissions is ever established. In 2010, the U.S. DOE Solar Energy Technology Office (SETO) announced unsubsidized PV price targets for 2020. Per their 2020 benchmarking, residential systems were 93% of the way towards achieving the target of 10 cents per kilowatt-hour (kWh) and commercial systems were 97% of the way towards the target of 8 cents/kWh. Systems met 2020 price targets three years early, and are progressing towards SETO's 2030 target for commercial PV of 4 cents/kWh (5 cents/kWh for residential PV systems). So, there is no question that, from an operational energy carbon emissions reduction perspective, PV systems are a cost effective and reliable choice.

Also, in States that allow investors to pay for the development of a solar system on someone else's property and then sell them the power that the system generates (aka Power Purchase Agreement, or "PPA"),³⁰ access to solar-generated electricity no longer has to be an "investment" decision. As long as the PPA provider can sell a customer electricity at a lower rate than the local utility company and can guarantee an escalation rate lower than the historical average for the local utility, owners have access to investment-free, risk-free solar systems. Thus, there are very few locations or projects that, given the current economics of PV systems, can justify not including the maximum amount of onsite solar generation resources.

³⁰ <https://www.seia.org/research-resources/solar-power-purchase-agreements>

³¹ The definition of resiliency from the National Research Council publication "Disaster Resilience: A National Imperative" 2012.

³² <https://www.cisa.gov/publication/niac-critical-infrastructure-resilience-final-report>

³³ https://content.naic.org/cjpr_topics/topic_climatenatural_catastrophe_risks_and_resiliency.htm

2.6.7_RESILIENCY

Onsite energy generation, in addition to many of the other decarbonization strategies discussed below, can help buildings "to prepare and plan for, absorb, recover from, and more successfully adapt to adverse events."³¹

Increases in the interruption of local utility supplies and excessive escalation of utility rates can adversely affect a property's asset value.

So, many of the strategies that make buildings better able to cope with the constant increase in the frequency of adverse events, also make a property more "valuable" to the occupants and, hence, the property owners.

Resiliency is a growing concern for many occupancy types. Design and construction strategies are needed to address disaster mitigation and recovery as well as passive operations: 24/7 facilities are especially ripe for benefiting from passive operational strategies (e.g. operable windows, exterior shading, super-insulated envelopes).

The National Infrastructure Advisory Council determined that resilience can be characterized by four key features: Robustness, Resourcefulness, Rapid Recovery, and Redundancy.³² The interrelationship between these four features and sustainability is shown in Figure 2.36 on the next page.

According to the National Association of Insurance Commissioners, "The economic cost of natural disasters has an immense impact on the U.S. economy. Natural catastrophes topped \$232 billion in total costs in 2019, with insured losses covering \$71 billion. In terms of insured losses, 10 of the nation's costliest catastrophes have occurred in the past two decades. Insurance plays a large part in helping with the economic recovery following catastrophic events. However, according to a 2019 Aon report, the portion of economic losses not covered by insurance (insurance gap) was \$161 billion."³³

Thus, one might argue that sustainable design and decarbonization strategies could be an effective form of "insurance" against the cost of adverse events.



2.0_UNIVERSAL DESIGN, CONSTRUCTION, AND OPERATIONAL PHASE CONSIDERATIONS

FIGURE 2.36: RISK, RESILIENCE, AND SUSTAINABILITY INTERRELATIONSHIPS

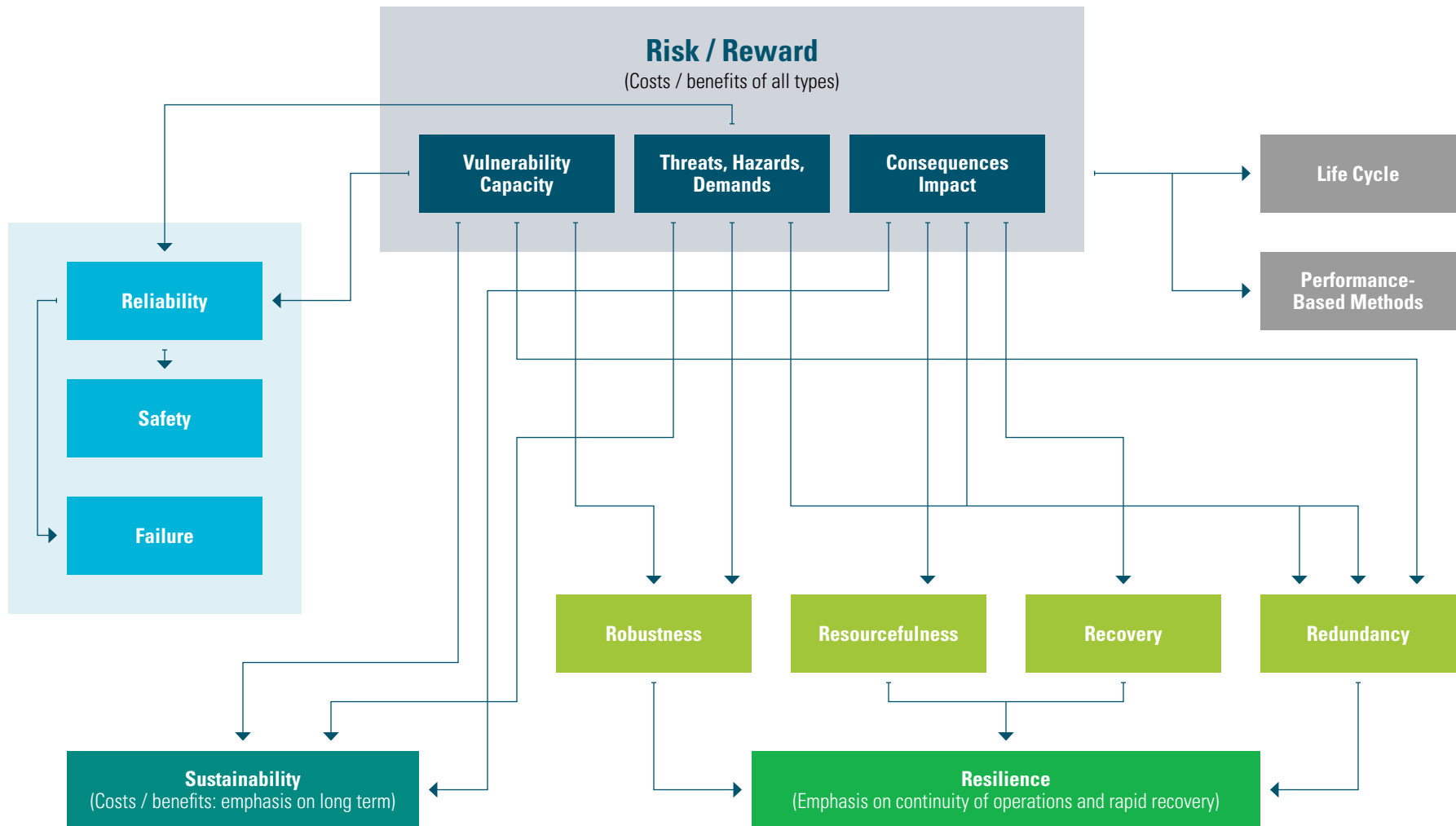

Source: <https://www.wbdg.org/resources/building-resiliency>

FIGURE 2.37: THE BUSINESS CASE FOR RESILIENCY INVESTMENTS

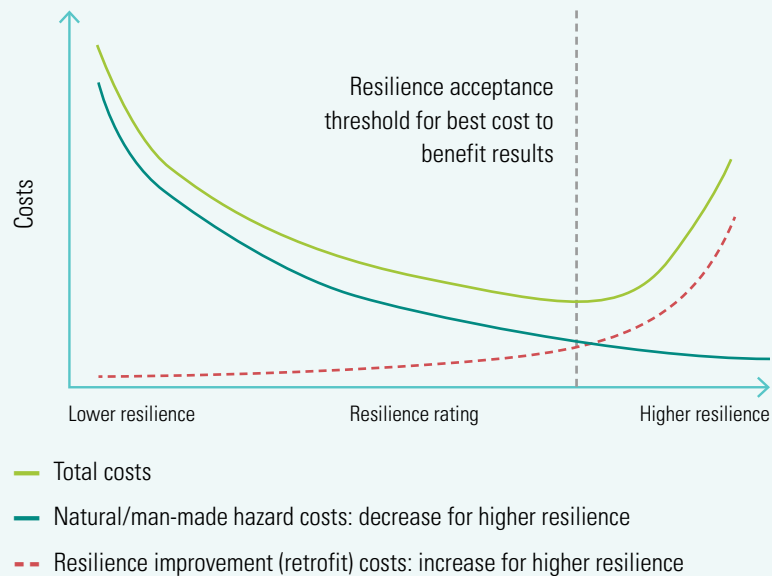

Source: The Business Case for Resiliency | <https://www.wbdg.org/resources/building-resiliency>

Going all-electric has proven to be a healthier and more resilient approach than conventional mixed-fuel designs. Insurance companies traditionally view resilience as a function of reduced impact from a natural disaster or increased speed of recovery (see Figures 2.37 and 2.38).

Data from recent disasters suggest that the speed of recovery of the utility infrastructure can be a severely limiting factor in a facility's resiliency, even if the facility itself is designed for maximum disaster preparedness.

FIGURE 2.38: SCENARIOS OF IMPROVED RESILIENCE

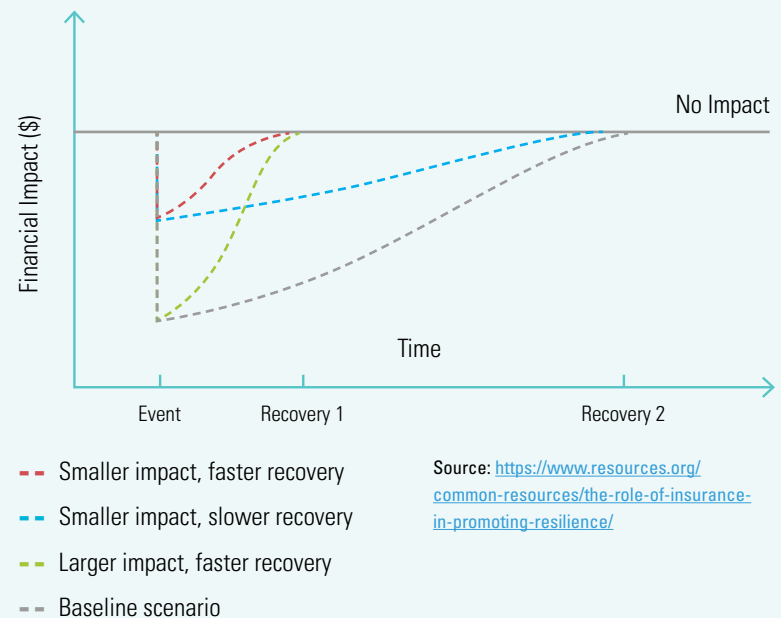

Source: <https://www.resources.org/common-resources/the-role-of-insurance-in-promoting-resilience/>

Data also suggests that utility companies' electrical infrastructure is inherently more resilient than their natural gas infrastructure (see Figure 2.39).

It turns out that many of the resiliency strategies promoted for decades as part of the "green building movement" can, indeed, increase a building's resiliency. In addition, the growing availability and popularity of building-scale battery energy storage systems make new strategies available for increasing the resiliency of buildings.

2.0_UNIVERSAL DESIGN, CONSTRUCTION, AND OPERATIONAL PHASE CONSIDERATIONS

FIGURE 2.39

EARTHQUAKES	Earthquake Damage to Services	Loma Prieta SF Bay Area (1989)	Northridge LA Area (1994)
	# of Electricity Outages	1.4 million	2.3 million
	Electricity — Time to Restoration	70% restored same day Most habitable structures restored in 5 days	99% restored in 7 hours Remaining habitable structures in 2 days
	# of Gas Outages	156,000	151,000
	Gas — Time to Restoration	80% restored in 10 days	80% restored in 14 days
	# of Gas Fires	30	158

HURRICANES & FLOODS	Flood Damage to Services	Hurricane Katrina New Orleans (2005)	Super Storm Sandy NY, NJ, WV (2012)
	# of Electricity Outages	2.5+ million 28,900 utility poles destroyed	8.5 million
	Electricity — Time to Restoration	10% restored within 3 days 75% restored after 23 days	95% restored within 13 days in NY Restored quicker in NJ and WV
	# of Gas Outages	105,000	87,000 +1,700 large buildings without steam service (in NY only)
	Gas — Time to Restoration	10 years to replace 162 miles of degraded piping 316 total miles repaired	2-3 weeks for full restoration of gas and steam 4 hospitals closed (no steam, but had power)

2.6.7.1_Microgrids, “Islanding,” and Resiliency

With the growing availability of building-scale Battery Energy Storage Systems (BESS), the ability to combine solar PV systems, batteries, generators, and other energy generation systems into an integrated system that can work in tandem with conventional utility power expands the opportunities for development of single-customer microgrids (see Figure 2.40). A byproduct of this configuration of systems is the ability to continue building operations despite a loss of grid-supplied power: when a building operates on a microgrid without utility power connected, this is called “islanding.”

FIGURE 2.40: MICROGRIDS AT DIFFERENT SCALES

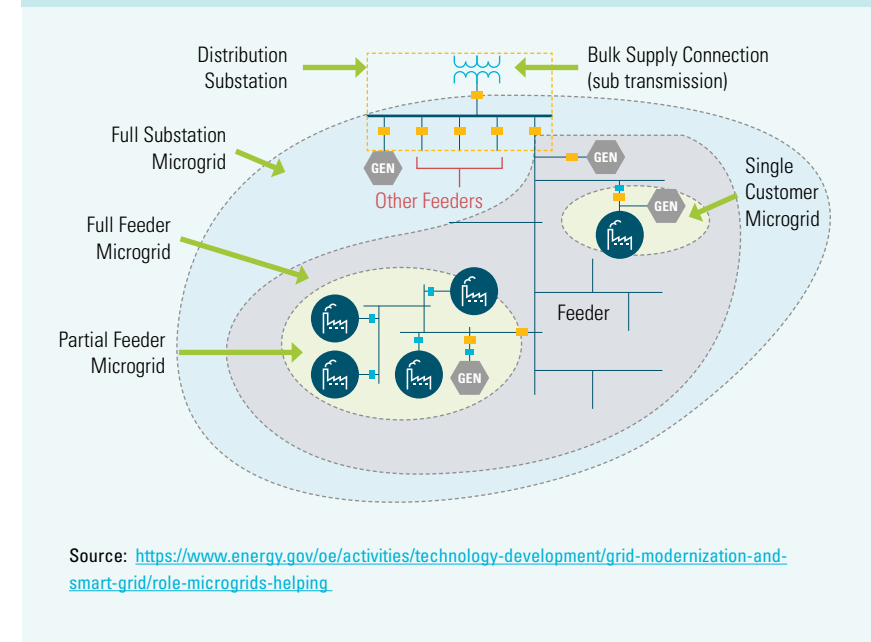

Source: <https://www.energy.gov/oe/activities/technology-development/grid-modernization-and-smart-grid/role-microgrids-helping>

2.0_ UNIVERSAL DESIGN, CONSTRUCTION, AND OPERATIONAL PHASE CONSIDERATIONS

Microgrids have traditionally been deployed to provide backup for the grid in case of emergencies. A microgrid can also be used to cut costs by replacing grid-sourced electricity with onsite generated electricity when onsite generation can be provided at a lower cost or when demand charges can be significantly reduced by lowering the demand from the utility grid. This approach has grown in popularity with decreases in the costs of solar and BESS coupled with rapidly advancing data processing capabilities.

Also, a microgrid can be used to connect to a local utility resource that is too small or unreliable for traditional grid use. Most importantly for the readers of this practice guide, a microgrid allows communities to be more energy independent and, in some cases, more environmentally friendly.³⁴ The availability of real-time and forecasted marginal emissions rates for utility power can be combined with weather and solar production forecasting to create opportunities to use a microgrid controller's optimization algorithms for managing microgrid resources in order to reduce the GHG emissions from operational energy use. Also, "the recent increase in natural and human-triggered threats like wildfires and severe storms has added urgency to microgrid development" for improved resiliency of buildings.³⁵ However, operating a microgrid in island mode is still subject to local utility company approval and may not currently be allowed in many locations. Growing interest in microgrids is now forcing utilities and regulators to rethink how the grid of the future will be designed and operated.

2.6.7.2_Operable Windows and Natural Ventilation

The purpose of this section is not to claim that operable windows and natural ventilation are the solution to reducing the energy intensity of building operations. However, it is common sense that if outdoor conditions are favorable and the building is properly designed to take advantage of it, natural ventilation can allow a building to be "comfortable" without a lot of energy use for mechanical cooling, heating, or ventilation. "Properly designed"

means that the building is intentionally configured to be well-suited for natural ventilation. It is a fact that operable windows alone do not make a building "naturally ventilated." Yet, research suggests that under the right conditions, operable windows can increase an occupant's sense of comfort.³⁶

But why are we talking about natural ventilation in a practice guide about all-electric buildings? It is as important to consider the use of operable windows to allow for maintaining comfort without using electrical energy for HVAC systems, as it is to recognize that improper use of operable windows can be problematic for energy use reduction and may even warrant active controls to ensure they are not used when HVAC systems are running.

When it comes to resiliency, however, it is also important to recognize that, increasingly, owners may need to figure out how to keep their buildings in operation during power failures, and operable windows can be extremely handy in these situations in lieu of more expensive and complex alternatives like generators and other advanced microgrid configurations.

2.6.7.3_Passive Heating and Cooling Strategies

As discussed in Section 2.5.1.1, reducing energy consumption has benefits for all-electric building design, cost, and GHG emissions performance. The most reliable form of energy efficiency is to turn off energy consuming systems. So, to the extent that, during certain times of the year, and under certain outdoor conditions, a building could achieve a passive energy balance that allows the indoor environment to remain "comfortable," passive heating and cooling strategies can potentially save significant amounts of energy.

Furthermore, when grid utilities are not available to run a building's heating and cooling systems, passive strategies tend to improve the habitability of the indoor environment over a broad range of outdoor conditions.

³⁴ <https://www.energy.gov/articles/how-microgrids-work>

³⁵ <https://www.utilitydive.com/news/microgrids-are-coming-will-they-increase-inequities/593133/>

³⁶ For example, see ASHRAE RP-1161, "Operable Windows, Personal Control, and Occupant Comfort", 2004.



Passive cooling actions generally include the following:

1. Storing of cold mass or air within building envelope

- » Night pre-cooling combined with thermal mass

2. Avoidance of direct external solar radiation heat gain

- » High performance glass in fenestration units
- » Shading glazed areas
- » Using landscape design
- » Design of self-shading forms
- » Color and reflectivity of external surfaces and interior surfaces exposed to direct solar radiation

3. Removal of gained heat from the interior or exterior sources

- » Night pre-cooling
- » Natural or whole-house exhaust ventilation
- » Earth tubes, rock beds, basement labyrinths (all ways to use thermal mass strategically)

4. Slowing heat transfer from the external climate through the building envelope

- » Super-insulation (e.g. Passive House)
- » Double or triple glazed fenestration units

Passive heating relies on many of the same strategies, applied in ways that tend to maximize the use of direct solar radiation for heating interiors during winter, while limiting the solar radiation impacts in summer.

Passive design strategies are covered extensively in a number of excellent design resources, and these resources should be sought out and applied when considering incorporation of passive design strategies in your project. For example, *Lo-TEK: Design by Radical Indigenism* by Julia Watson, does an amazing job of cataloguing “sustainable, adaptable, and resilient technologies that are borne out of necessity,” although by no means is the book intended to be a manual on passive design strategies for the built environment. Similarly, *Architecture without Architects* by Bernard Rudofsky, published in 1964, acknowledges that the wisdom to be derived from the “art of building” practiced centuries ago “goes beyond economic and aesthetic considerations, for it touches the far tougher and increasingly troublesome problem of how to live and let live, how to keep peace with one’s neighbors, both in the parochial and universal sense.” Both books reveal the richness of indigenous science that emerges from the lessons of place, climate, and survival, provide insight into the effectiveness of passive design strategies, and help us gain a perspective on why equity must be a central consideration in achieving the larger goals of a decarbonized built environment.

2.6.8 _ WATER USE REDUCTION AND BUILDING ELECTRIFICATION SYNERGIES

While the focus of this practice guide is on decarbonization of the built environment through the all-electric design of buildings, we need to remember that the consequences of climate change and the current lifestyle of modern societies adversely impacts our most precious resource: potable water, which is truly “the stuff of life.” In fact, incorporating water conservation has a number of synergies with building electrification.

2.6.8.1 _ Reduced Domestic Hot Water Usage

Reducing domestic hot water (DHW) use has the benefit of reducing potable water consumption and, at the same time, reducing energy consumption and water heating system first cost.

2.0_ UNIVERSAL DESIGN, CONSTRUCTION, AND OPERATIONAL PHASE CONSIDERATIONS

Strategies for reducing DHW use include:

1. Low flow shower heads:

- » If supply water pressures are adequate, shower heads are available that can provide a “comfortable” shower at flow rates as low as 1.25 GPM,³⁷ or half the flow rate of most “high-efficiency” shower heads on the market today.

2. Sewer water energy exchange (SWEE):

- » Discussed as a building scale technology in Sections 2.6.2.2, there are point of use technologies that can preheat cold water before it is mixed with hot water at an outlet for creating the right use temperature. Often referred to as “drain water heat recovery,” this application uses engineered heat exchangers installed in wastewater piping from fixtures and appliances (e.g. showers and dishwashers) to exchange energy between the hot water in the wastewater piping and the cold water inlet to various fixtures (see Figure 2.41). The increased temperature of the cold water used at the fixture allows for a reduced amount of hot water to be used to achieve the same outlet temperature.

3. Appliances:

- » Look for appliances that have the lowest water use and are rated by a national standard such as EPA’s EnergyStar and WaterSense standards, or ratings of Tier 2 and higher by the Consortium for Energy Efficiency if performance superior to the EPA Standards are of interest.

FIGURE 2.41: DRAIN WATER HEAT RECOVERY

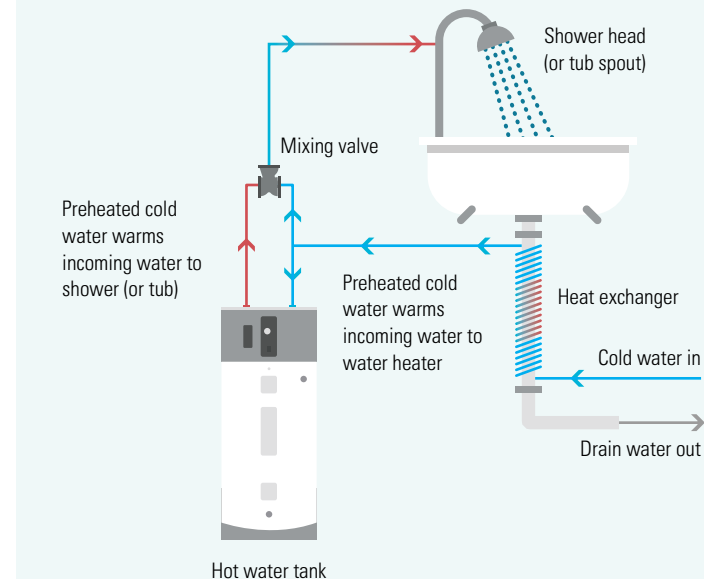

While other Volumes of this practice guide discuss ways to electrify DHW production, as well as reduce energy use for other aspects of the DHW system, water conservation strategies are not the primary focus herein. Look instead to other water conservation resources for further discussion on usage reduction strategies.

³⁷ For example, see Niagara showerhead products at <https://products.amconservationgroup.com/browse-products/water/showerheads>.

2.6.8.2_Recognition of the Water-Energy Nexus

For the vast majority of buildings, potable water arrives via a series of pipes from a local water treatment plant. Most drinking water treatment plants utilize energy-intensive processes to treat, pump and distribute high volumes of water to their customers. Researchers at the University of Texas at Austin have attempted to quantify the energy embedded in the U.S. public water supply, which is the primary water source of residential, commercial, and municipal users. One such analysis concluded that energy use associated with the public water supply is 4.1% of the nation's annual primary energy consumption and 6.1% of national electricity consumption, but this analysis excluded energy requirements associated with water for agriculture, industrial, and self-supplied sectors (e.g. thermoelectric and mining).³⁸ The American Water Works Association Research Foundation reported energy use for potable water treatment and delivery in the U.S. to be in the range of 0.07 – 0.92 kWh/m³, with an estimated average of 0.38 kWh/m³.³⁹ Furthermore, the energy demand for water infrastructure is projected to increase by approximately 30 percent over the coming decades.

All of this data suggests that a significant amount of GHG emissions are “embedded” in the water we use in our buildings. So, in addition to reducing the impact of droughts and general resource scarcity, water efficiency can reduce GHG emissions related to fossil-fuel use within the water service system.

While this practice guide is focused on decarbonization of the built environment, we must recognize the essential role that water plays in sustaining life. Thus, the most sensible water conservation strategy (regardless of energy use considerations) is to preserve the highest quality drinking water for human consumption, and to use lower quality water resources for as many “non-contact” uses as possible. This usually means developing onsite water treatment and reuse systems, unless a building happens to be situated in one of the few areas serviced by municipally-supplied reclaimed water.

³⁸ “Energy-Water Nexus: The Water Sector’s Energy Use”, Congressional Research Service, January 24, 2017

³⁹ See https://roanoke.com/opinion/commentary/younos-carbon-footprint-of-community-water-consumption/article_3359937d-ab7c-5f65-9f7f-c54490831d52.html

2.6.8.3_Onsite Water Treatment and Reuse

Different reuse strategies and technologies have a range of space and energy use requirements. The more natural or passive water reuse and recycling pathways, such as constructed wetlands, require little energy to operate but a great deal of space. On the other hand, a membrane bioreactor system may require considerable energy to operate but can occupy a relatively small footprint in the building. It is incumbent upon the design team to balance the competing goals of potable water use reduction, increased resilience, and energy use reduction when exploring onsite water reuse options.

The first practice guide produced by the William J. Worthen Foundation (known then as the Urban Fabrick Collaborative) was the “Onsite Non-Potable Water Reuse Practice Guide,” published in January 2018 and available for free download at <https://www.collaborativedesign.org/water-reuse-practice-guide>. The Top 10 reasons why the A/E/C community should care about onsite non-potable water reuse, as outlined in the Water Reuse Practice Guide, have not changed much in the years since its publication:

- 1. It reduces a building’s need for potable water.**
- 2. It extends our water supply.**
- 3. It increases the resiliency of our cities and urban neighborhoods.**
- 4. It can reduce the costs of expanding and upgrading water and sewage infrastructure.**
- 5. It can allow projects to better achieve green building certifications without altering the architectural design.**
- 6. When done right, it is safe, cost-effective, and publicly acceptable.**



2.0_UNIVERSAL DESIGN, CONSTRUCTION, AND OPERATIONAL PHASE CONSIDERATIONS

7. It can be a cost-effective strategy to move your project closer to net-zero energy and water use.
8. It can be used as a tool to shorten planning and entitlement reviews.
9. Understanding how to address the water-energy nexus in practice is a great way to demonstrate professional leadership and environmental stewardship.
10. Eventually, onsite non-potable water reuse will not only be allowed but may be required in your jurisdiction.

Implementing small-scale decentralized water-reuse infrastructure combined with renewable energy systems is both carbon-responsible and resource-responsible, and all available alternative water sources should be considered for collection and reuse (see Figure 2.42). Reducing the use of potable water for everything other than human consumption should be a part of a project's decarbonization strategies.

2.6.8.4 _Be Careful About Trading Water Use for Energy Use

Evaporative cooling is a very energy efficient source of cooling when the local climate enables this technology to be used. However, this can become an extremely large potable water use in a building. For regions where water supplies come from local watersheds and are abundant, a decision to use evaporative cooling — climate permitting — may be a good trade-off for refrigerant-based cooling systems. However, as more and more regions become water stressed, and adequate clean drinking water resources become harder to maintain, all-electric buildings powered by 100% renewable energy will need to be the primary strategy for the building sector's response to climate change mitigation, and potable water will need to be preserved for its most important uses.

FIGURE 2.42: ALTERNATIVE WATER SOURCES

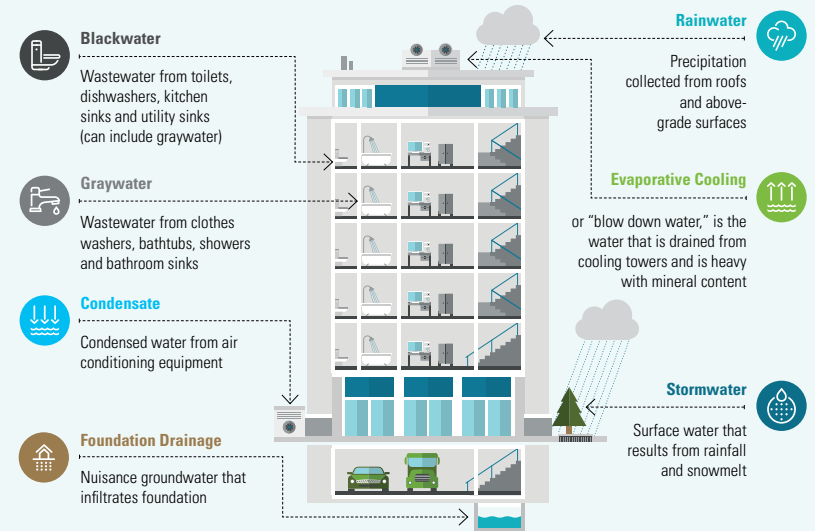

This diagram shows the main alternative water sources available in a typical urban building.

Source: Taken from "Onsite Non-Potable Water Reuse Practice Guide"

2.7 Construction Practices

According to a study by the University of Leeds and C40 Cities (the international cities network), “a 44% reduction in emissions could be achieved in the procurement and construction process if the industry did five things: 1) used materials more efficiently; 2) used existing buildings better; 3) switched to lower-emission materials; 4) developed and used low-carbon cement; 5) recycled building materials and components.”⁴⁰

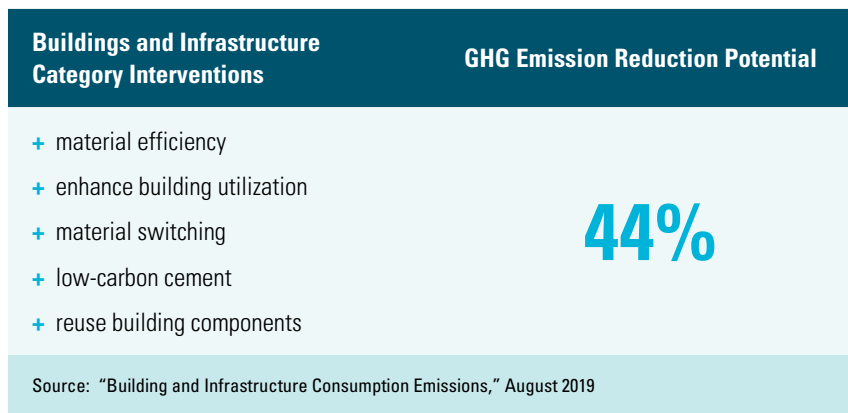

In addition, the use of low-emissions construction machinery is another intervention whose benefits are undisputed, but the data to quantify all of them is currently not available. These emissions are local and thus have a greater impact on air and noise pollution in dense urban environments. For example, it has been estimated that 14.5% of PM2.5 matter in London is due to local construction sites.⁴¹

The same report identifies and analyzes interventions to reduce consumption emissions from buildings and infrastructure construction, and scenarios are presented to show how consumption-based emissions in C40 cities may evolve if no action is taken, if limited action is taken, and if ambitious action is taken.

An approach to quantifying a construction program’s impacts on lifetime carbon emissions for a project can be found in “Whole Life Carbon Assessment for the Built Environment,” published by the Royal Institution of Chartered Surveyors (RICS) in 2017.⁴²

One of the hidden barriers to decarbonizing construction practices is the impacts to construction schedules from alternate materials and alternate approaches. For example, to the extent that the use of low carbon cement substitutes require longer curing times, this can adversely impact construction costs if not properly accounted for during the planning phases.

Furthermore, properly executed building enclosure commissioning (BECx) will require interruptions in erection sequences so that inspection and testing can be performed at a time when construction assemblies are still exposed to view, and when testing can inform the need for modifications to the design or installation methods before errors are repeated. BECx in combination with MEP systems commissioning is a vital strategy for ensuring that the decarbonization goals embedded in the design documents are faithfully delivered.

2.7.1 COMMISSIONING

Commissioning is a quality assurance strategy that has benefits for any modern construction project. A commissioning agent with prior experience in the design, start-up, and turn-over of the strategies that are common in all-electric buildings can be a valuable asset for navigating the unique challenges encountered in the design and construction of these projects.

⁴⁰ “Building and Infrastructure Consumption Emissions”, August 2019. Available from https://www.c40knowledgehub.org/s/article/In-Focus-Building-and-infrastructure-consumption-emissions?language=en_US.

⁴¹ “Zero Emission Construction Sites: The Possibilities and Barriers of Electric Construction Machinery”, Bellona Europa, 2019. Available at: <https://bellona.org/publication/zero-emission-construction-sites-the-possibilities-and-barriers-of-electric-construction-machinery>.

⁴² Available at: <https://www.rics.org/profession-standards/rics-standards-and-guidance/sector-standards/building-surveying-standards/whole-life-carbon-assessment-for-the-built-environment>

2.0_ UNIVERSAL DESIGN, CONSTRUCTION, AND OPERATIONAL PHASE CONSIDERATIONS

Among the most important aspects of commissioning these project types are:

1. Verify that contractors build per the design, purchase the correct equipment, and know how to install and start-up the equipment.

- › An example of an item to pay particular attention to is the configuration and start-up of central domestic hot water heating systems.
 - For a discussion of configuration considerations, see Section 2.6.2.3.
 - Central HPWHs require a sophisticated start-up that may be unfamiliar to plumbing contractors. The refrigeration circuit of a heat pump water heater requires the verification, and possible adjustment of, expansion valves as well as superheat and subcool settings of the system, checking for adequate refrigerant charge, and adding refrigerant if necessary (which requires a technician with an EPA 608 certification, more commonly found amongst HVAC contractors).

2. Ensure that facility operations staff are fully trained, especially on systems they do not have extensive prior experience with.

3. Make sure a Systems Manual is provided. Systems Manuals (see the LEED v4 for Building Design and Construction Enhanced Commissioning credit for more detail on Systems Manuals) compile documents critical for the proper operation and ongoing maintenance of systems. When dealing with new technology, Systems Manuals can be a key resource for operations staff.

4. Ensure the envelope performance of the building: validating that the installed enclosure meets performance expectations requires both witnessing installation (especially observing that performance control layers are installed properly before they are concealed within the construction) and testing the installed systems for proper performance (thermal, air, water control, etc.).

› Properly witnessing installation and testing requires coordinating trade schedules and sequencing to allow for these tasks at appropriate milestones in the overall enclosure installation. It's important to note that the current standard of practice for enclosure installation (a "continuous" installation sequence) typically needs to be modified to a non-traditional "start-stop-start" installation sequence to accommodate these commissioning tasks.

- Enclosure system installation should stop after an initial installation, in order to test the initial install and identify modifications that may be needed to pass thermal, air and water control tests. Only then should installation restart, and subsequent system and component installations must incorporate the required modifications.
- Start-stop-start sequencing, when properly coordinated into the General Contractor's installation schedule in advance, will usually be perceived as inefficient and costly. However, the added cost should be seen as a reasonable "insurance policy" against the potential costs and delays in the event that the envelope systems fail their performance tests. These added costs typically include:
 - › the additional time and materials for de-installing, remediating, and re-installing work that may have been installed before testing could be accomplished, and which now needs post-test modifications, and
 - › the financial hardship and potential litigation costs for enclosure remediation and repairs to address interior damage if issues are not found until after project handover.
- System/components testing needs to occur before interior finishes are installed, to allow for:
 - › proper viewing of any water or air infiltration issues, and

- › limiting damage to and therefore removal and replacement of interior finishes if there is a problem (i.e. wetting and degradation of sheetrock, wetting and potential for mold in interstitial insulation, etc.).
- Even when agreeing to start-stop-start erection sequencing, when schedule challenges occur (as they often do) General Contractors will typically want to modify previously agreed enclosure erection sequencing. They may offer to "continue at risk" and/or "accept full responsibility during the warranty period." Owners would be well-advised to resist these "concessions." Due to the multiple trades involved in an enclosure, if issues arise there will be finger pointing and litigation before issues are resolved. This may leave the owner or occupants with a building that is partially or totally unusable until these problems are resolved.

5. Oversee the proper handling of substitutions during construction:

- › The critical features of equipment may not always be recognized or understood by the contractors or their vendors. Ensuring the "equivalency" of all aspects of substituted equipment can be important to avoid surprises at the end of a project. It is disappointing, and possibly even negligent, when key goals of the owner have been unknowingly sacrificed as a result of acceptance of substitutions by the Engineers of Record.
- › When onsite renewable energy systems are sized to produce a certain amount of electricity annually — based on the predicted consumption of the building's all-electric systems — equipment substitutions can adversely affect both energy consumption and production, and hence the carbon footprint of the final facility.

2.8 _ Post-Construction Practices

2.8.1 _ MONITORING-BASED COMMISSIONING AND RETRO-COMMISSIONING

Commissioning during the post-construction or operations phase of a building's life cycle is fundamentally different from the commissioning that occurs during the construction phase.

MONITORING-BASED COMMISSIONING (MBCX)

During the first year of operation and beyond, utilizing data collected about building system and equipment performance can be extremely effective in identifying and addressing the operational issues that cause systems to operate in manners that diminish performance, increase energy use, and cause operator and end user dissatisfaction.

Many terms are used for this activity: data analytics, fault detection and diagnostics (FDD), data-driven facilities management, etc. All these terms have at their core the fundamental concept of gathering data from systems that control and monitor building equipment to provide an on-going methodology for identifying and correcting system performance issues. Thus, Monitoring-based Commissioning is a term that encapsulates the process of collecting and analyzing data and responding to system anomalies with corrective actions.

MBCx helps identify operational issues that can be hard to discover during the construction phase commissioning work that is done prior to building turn-over to an owner. Construction phase commissioning tends to look at the operation of systems through demonstration of changes to specific, short-term operational conditions that need to result in appropriate systems responses. However, the dynamic operation of systems in response to the occupants' use of a building results in more complex system interactions than can be created during initial testing. Thus MBCx can be an essential step towards successful and efficient building operations.

Key steps for maximizing the benefits of MBCx include:

1. Engage the building operations team early.

- » The operations team is the ultimate stakeholder of monitoring-based commissioning. The end goal should be to train the operations team to facilitate monitoring-based commissioning, and to commit to taking action on identified issues.

2. Look into incentive programs.

- » Federal funds, state grants, and utility incentives may be available to offset the first costs of monitoring-based commissioning. Where formal programs don't exist, municipalities and utilities are usually willing to entertain a pilot program when you work with an approved service provider.

3. Choose Automated Fault Detection and Diagnostics (AFDD) software that is customizable and capable of integrating with a Building Automation and Control System.

- » MBCx can be implemented very cost-effectively by employing any of a variety of well-developed platforms that “automate” the collection and analysis of the large amounts of data available in most modern commercial buildings.
- » ASHRAE Guideline 36, “High-Performance Sequences of Operation for HVAC Systems,” has integrated many automated FDD functions and is a good resource for understanding how FDD can be used for maintaining proper system performance.
- » A vast number of third-party automated FDD providers offer both open protocol and platform-specific products.

2.8.2_RETRO-COMMISSIONING AND RECOMMISSIONING

Retro-commissioning is generally considered a process to improve an existing building's performance. Opportunities for performance improvement are identified, quantified, implemented, and demonstrated to result in energy savings or other operational improvements. According to a 2005 study by Lawrence Berkeley National Laboratory, PEI and the Energy Systems Laboratory at Texas A&M University, median payback for retro-commissioning was 8.5 months (https://www.bcxa.org/ncbc/2005/proceedings/19_Piette_NCBC2005.pdf), and was at the time the most cost-effective means of improving energy efficiency in commercial buildings.

Recommissioning is another type of commissioning that occurs when a building that has already been commissioned undergoes another commissioning process. The decision to recommission may be triggered by a change in building use or ownership, the onset of operational problems, or some other need. Ideally, a plan for recommissioning is established as part of a new building's original commissioning process. The Enhanced Commissioning credit in LEED v4 BD&C requires the Commissioning Agent to develop an “Ongoing Commissioning Plan,” providing the building's operating staff with procedures, blank test scripts, and a schedule for recommissioning activities.

The growth of interest in recommissioning stems from a study by Portland Energy Conservation, Inc. (PECI) completed decades ago, suggesting that the benefits of new construction commissioning do not always persist.⁴³ The study identified three main reasons that the benefits did not persist:

1. **Limited operator support and high operator turnover rates**
2. **Poor information transfer from the new construction commissioning process**
3. **A lack of systems put in place to help operators track performance**

⁴³ Available at: https://www.aceee.org/files/proceedings/2002/data/papers/SS02_Panel3_Paper11.pdf

The persistence of commissioning benefits were found to be highly dependent on the working environment that included adequate operator training, dedicated operations staff with the time to study and optimize building operations, and an administrative focus on building performance and energy costs. Four methods for improving persistence were proposed:

- » **Providing operators with a high level of training and support.**
- » **Providing a complete Systems Manual at the end of the commissioning process.** The systems manual is the institutional memory for the building, and this information assists the staff in ensuring that the benefits of commissioning persist. If the knowledge gained from the commissioning process is not available to the current operators, the value of commissioning is decreased in the long term.
- » **Tracking building performance.** While not common at the time the PECI study was completed, this can best be done through an MBCx process using automated FDD platforms.
- » **Starting commissioning in the design phase.** The most cost effective benefits of commissioning often occur during the design phase, when changes can be made on paper, rather than during construction or after construction is complete.

2.8.3_DECONSTRUCTION

Deconstruction is the final chapter in the life cycle of a building. Proper and thoughtful planning for the entire life of a building project — from the initial design to the end of its useful life — can ensure that the entire lifetime carbon impact of a construction project is minimized, with the ultimate goal that construction projects achieve lifetime carbon neutrality.

While carbon neutrality is a laudable goal, it is but one positive effect of deconstruction (which is sometimes called “construction in reverse” or “unbuilding”) instead of outright demolition (which typically uses mechanical equipment like bulldozers and wrecking balls, resulting in limited reusability). Other positive impacts, according to Building Reuse, a non-profit organization focused on reusing building materials, include fewer trips to landfills, job creation and workforce development, and aftermarket opportunities to reuse or recycle building materials. Public health is also served by deconstruction, considering that demolition can release harmful lead dust, asbestos, and other toxic materials into the community.⁴⁴

Green building certifications also encourage and reward deconstruction and building material reuse and recycling efforts. Moreover, municipalities are implementing deconstruction policies to achieve their triple-bottom-line sustainability goals.⁴⁵ The deconstruction industry has the potential to create stable jobs with low training thresholds, foster community connections, and contribute to more sustainable construction practices.

⁴⁴ From [Build Reuse](#).

⁴⁵ See <https://www.portland.gov/bps/decon/deconstruction-requirements> and https://www.c40knowledgehub.org/s/article/How-to-start-deconstructing-and-stop-demolishing-your-citys-buildings?language=en_US



ACKNOWLEDGMENTS

—
Project Sponsors, Contributors,
and Terms of Use

Project Sponsors



At Google, sustainability is at the core of everything we do. We tackle environmental sustainability projects because they reduce our company's environmental impact, and also because they help our bottom line. But mostly we do it because it needs to be done and it's the right thing to do. And we're not just saying that. Google has been carbon neutral since 2007. We believe this Building Decarbonization Practice Guide is a great tool that will help enable design and engineering teams everywhere to deliver water innovation for residential and office-space projects of all scales.



At Microsoft, we believe sustainability is critical for meeting the economic, societal, and environmental needs of today and of future generations. We also believe sustainability is good for business.



Energy Foundation supports education and analysis to promote non-partisan policy solutions that advance renewable energy and energy efficiency while opening doors to greater innovation and productivity — growing the economy with dramatically less pollution. For nearly 30 years, Energy Foundation has supported grantees to help educate policymakers and the general public about the benefits of a clean energy economy. Our grantees include business, health, environmental, labor, equity, community, faith, and consumer groups, as well as policy experts, think tanks, universities, and more.



UL is the global safety science leader. We deliver testing, inspection and certification (TIC), training and advisory services, risk management solutions and essential business insights to help our customers, based in more than 100 countries, achieve their safety, security and sustainability goals. Our deep knowledge of products and intelligence across supply chains make us the partner of choice for customers with complex challenges. Discover more at [UL.com](https://www.ul.com).



AIA California represents the interests of more than 11,000 architects and allied professionals in California. Founded in 1944, the AIA California's mission supports architects in their endeavors to improve the quality of life for all Californians by creating more livable communities, sustainable designs and quality work environments. For more information, visit [aiacalifornia.org](https://www.aiacalifornia.org).



The Building Decarbonization Coalition unites building industry stakeholders with energy providers, environmental organizations and local governments to help electrify California's homes and work spaces with clean energy. Through research, policy development, and consumer inspiration, the BDC is pursuing fast, fair action to accelerate the development of zero-emission homes and buildings that will help California cut one of its largest sources of climate pollution, while creating safe, healthy and affordable communities. The Project Team gives special thanks to the BDC for its leadership in this endeavor and for the generous support of its Membership.

WRNSSTUDIO



Contributors

Building Decarbonization Practice Guide Content Leadership

- » **Panama Bartholomy**, Building Decarbonization Coalition
- » **Rachelle Boucher**, Kitchens to Life
- » **Glenn Friedman**, PE, FASHRAE, Taylor Engineers
- » **Christopher Galarza**, Forward Dining Solutions
- » **Miranda Gardiner**, AIA, iMasons Climate Accord
- » **Steven Guttman**, PE, BCxP, LEED Fellow, Guttman & Blaevoet
- » **Teresa Jan**, AIA, LEED AP, WELL AP, Multistudio
- » **Heidi Lubin**, eSix Development
- » **Kyle Pickett**, William J. Worthen Foundation
- » **Katie Ross**, Microsoft
- » **Pauline Souza**, FAIA, LEED Fellow, WELL AP, LEED AP BD+C, LFA, WRNS Studio
- » **Alice Sung**, AIA, LEED AP BD+C, SEA, Greenbank Associates
- » **Ted Tiffany**, LEED AP BD+C, Building Decarbonization Coalition

Project Manager

- » **Brett Rosenberg**, LEED AP, Cushman & Wakefield

WJWF Intern

- » **Laura Barbosa**, Construction Industry Workforce Initiative

Graphic Design

- » **Stoller Design Group**

Copy Editor

- » **Geoff Martin**, Wheelhouse Writing Services

Working Group Members and Content Contributors

- » **Katie Ackerly**, AIA, David Baker Architects
- » **Sean Armstrong**, Redwood Energy
- » **Heather Burpee**, University of Washington Integrated Design Lab
- » **Don Davies**, PE, SE, Magnusson Klemenic Associates
- » **Pierre Delforge**, Natural Resources Defense Council
- » **Patrick Doss-Smith**, HGA
- » **Susan Freed**, County of San Diego
- » **Andreas Gyr**, Google
- » **Ryan Hamilton**, Consortium for Energy Efficiency
- » **Barry Hooper**, SF Environment
- » **Josh Jacobs**, LEED AP+ BD&C, UL
- » **Dirk Kestner**, PE, LEED AP BD+C, ENV SP, Walter P Moore
- » **Bruce King**, Ecological Building Network
- » **Candice Kollar**, Kollar EcoCreative and William J. Worthen Foundation
- » **Meghan Lewis**, Carbon Leadership Forum
- » **Lisa Fay Matthiesen**, FAIA, LEED Fellow, Amazon
- » **Maurya McClintock**, McClintock Facades Consulting, LLC
- » **Hilary Noll**, AIA, LEED AP BD+C, Mithun
- » **Kelsey Rose Price**, PE, Hines
- » **Cole Roberts**, PE, LEED AP, WELL AP, Arup
- » **Henry Siegel**, FAIA, LEED AP, Siegel + Strain Architects
- » **Stacy Smedley**, Skanska
- » **Larry Strain**, Siegel + Strain
- » **Mark Webster**, PE, LEED AP BD+C, Simpson Gumpertz & Heger
- » **Wolfgang Werner**, AIA, LEED AP BD+C, CPHD, Urban Fabrick, Inc.
- » **Breana Wheeler**, BRE (BREEAM USA)
- » **Tamim Younos**, Green Water-Infrastructure Academy



Terms of Use

Please read the following Terms of Use (“the Terms”) carefully before accessing or using “The Building Decarbonization Practice Guide: A Zero Carbon Future for the Built Environment” (“the Book”). These Terms govern your use of the Book, and by accessing or using it, you acknowledge and agree to be bound by these Terms. If you do not agree with any part of these Terms, you should not access or use the Book.

1. Intellectual Property Rights:

- a. All intellectual property rights in the Book, including but not limited to copyrights, trademarks, and any other rights, belong to the William Worthen Foundation (“the Publisher”) or have been appropriately licensed by the Publisher. The Book is protected by applicable copyright and other intellectual property laws.
- b. The Publication and its original content, features, and functionality are owned by the Publisher and are protected by international copyright, trademark, patent, trade secret, and other intellectual property or proprietary rights laws.
- c. You may not reproduce, distribute, modify, create derivative works of, publicly display, publicly perform, republish, download, store, or transmit any part of the Book without the prior written consent of the Publisher, except as expressly permitted by applicable law and as outlined in these Terms.

2. Permitted Use:

- a. You are granted a non-exclusive, non-transferable, limited license to access and use the Book solely for your personal informational and educational purposes.
- b. You may make copies of the Book for your personal use, such as storing it on your personal devices or printing a copy for personal reading. However, you may not distribute or share these copies with others.

- c. You are granted a non-exclusive, non-transferable, limited license to place a link on your own website to the Worthen Foundation website (<https://worthenfoundation.org/get-the-guide-bdpg>), where the Book can be downloaded by others who will also be required to be bound by the Terms.
- d. You may use the text from the Book for personal, non-commercial purposes with the appropriate attribution substantially in the form of: “Material presented is taken from ‘The Building Decarbonization Practice Guide’ published by the William Worthen Foundation, and is reprinted with permission of the Foundation.”

3. Prohibited Use:

- a. You may not use the Book in any way that violates applicable laws or regulations.
- b. You may not use the Book or its contents for any commercial purpose without the explicit written consent of the Publisher. Should uses other than those permitted above be desired by the user, the Publisher will consider written requests, and the Publisher may require monetary and/or in-kind compensation in order to grant such a request. Use of material from the Book for commercial purposes is not permitted unless a separate agreement is executed between you and the William Worthen Foundation.
- c. You may not modify, adapt, reverse engineer, decompile, or disassemble the Book or any part of it.



Terms of Use (continued)

- d. You may not remove, alter, or obscure any copyright, trademark, or other proprietary notices contained in the Book.
- e. You may not use any images, including photographs and graphics, in the Book without the explicit written consent of the Publisher.
- f. You may not host links to downloadable copies of the Book on any website. All copies of the Book shall be exclusively acquired by direct download from the William Worthen Foundation website (<https://worthenfoundation.org/get-the-guide-bdpg>).

4. Limitation of Liability:

- a. The Book is provided on an "as is" basis, without warranties of any kind, either expressed or implied. The Publisher disclaims all warranties, including but not limited to, warranties of title, merchantability, fitness for a particular purpose, and non-infringement.
- b. In no event shall the Publisher be liable for any direct, indirect, incidental, special, exemplary, or consequential damages arising out of or in connection with the use of the Book, even if advised of the possibility of such damages.

5. Indemnification:

- a. You agree to indemnify and hold harmless the Publisher and its affiliates, officers, agents, employees, and partners from any claim or demand, including reasonable attorneys' fees, made by any third party due to or arising out of your use of the Publication, your violation of this Agreement, or your violation of any rights of another.

6. Termination:

- a. The Publisher reserves the right to suspend or terminate your access to the Book at any time, without prior notice, for any reason or no reason, in their sole discretion. If access to the Book is suspended or terminated, you agree to stop accessing the Book and/or delete all copies of the Book as instructed by the Publisher.

7. Changes to the Terms:

- a. The Publisher reserves the right to modify or update these Terms at any time without prior notice. The most current version of the Terms will be posted on the Publisher's website or provided with the Book. Your continued use of the Book after any modifications or updates to the Terms constitutes your acceptance of such changes.

8. Governing Law and Jurisdiction:

- a. These Terms shall be governed by and construed in accordance with the laws of the State of California. Any disputes arising out of or in connection with these Terms shall be subject to the exclusive jurisdiction of the courts located in California.

By accessing or using the Book, you acknowledge that you have read, understood, and agree to be bound by these Terms. If you do not agree to these Terms, you should not access or use the Book.

For questions or licensing requests, please contact **Kyle Pickett** at kyle@worthenfoundation.org, or **Candice Kollar** at candice@worthenfoundation.org.

